

# USER MANUAL

---

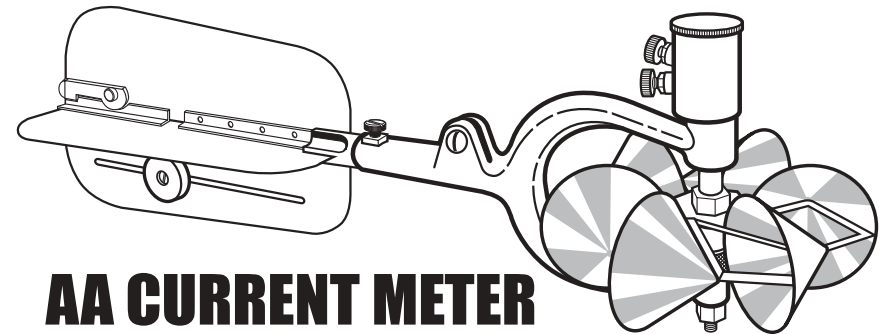

**AA CURRENT METER**

## **Precision Hydrological Tool for Water Current Measurement**

---

### **Rickly Hydrological Co.**

1700 Joyce Ave. • Columbus, OH 43219  
PH: 614-297-9877      www.rickly.com  
FAX: 614-297-9878      E-Mail: sales@rickly.com

**Rickly Hydrological Co.** 1700 Joyce Ave. • Columbus, OH  
**614-297-9877**

**TABLE OF CONTENTS**

**INTRODUCTION** ..... 1

**METER ASSEMBLY** ..... 2

**METER MAINTENANCE** ..... 2

    Before a Field Trip ..... 2

    After a Field Trip ..... 3

**STORAGE** ..... 6

**RECORD KEEPING** ..... 6

**RATING CHART IN FEET PER SECOND** ..... 7

**RATING CHART IN METERS PER SECOND** ..... 8

**WARRANTY**

Rickly Hydrological Co., Inc. warrants that its products are free from defects in material and workmanship under normal use and service for a period of one year from date of shipment from the factory.

Rickly Hydrological's obligations under this warranty are limited to, at Rickly Hydrological's option: (I) replacing or (II) repairing any products determined to be defective. In no case shall Rickly Hydrological's liability exceed the product original purchase price. This warranty does not apply to any equipment that has been repaired or altered, except by Rickly Hydrological Co., Inc., or which has been subject to misuse, negligence or accident. It is expressly agreed that this warranty will be in lieu of all warranties of fitness and in lieu of the warranty of merchantability. The warranty begins on the date of the invoice.

*Copyright © 2006 Rickly Hydrological Co., Inc.. All Rights Reserved. This manual may not be disclosed, copied, reproduced, modified or distributed without the express written permission of Rickly Hydrological. Permission is granted to the Customer to view, store, reproduce and distribute this manual to its employees for equipment training and maintenance purposes only, provided that none of the pages are modified and this page is included in any distribution.*

**METRIC STANDARD RATING TABLE NO. 2 FOR AA CURRENT METERS (G/99) - VELOCITY IN METERS PER SECOND**

TIME IN SECS	REVOLUTIONS																	
	3	5	7	10	15	20	25	30	40	50	60	80	100	150	200	250	300	350
40	0.056	0.089	0.123	0.173	0.257	0.341	0.425	0.509	0.677	0.845	1.013	1.349	1.685	2.526	3.366	4.206	5.046	5.886
41	0.055	0.087	0.120	0.169	0.251	0.333	0.415	0.497	0.661	0.825	0.989	1.317	1.645	2.464	3.284	4.103	4.923	5.742
42	0.053	0.085	0.117	0.165	0.245	0.325	0.405	0.485	0.645	0.805	0.965	1.285	1.605	2.406	3.206	4.006	4.806	5.606
43	0.052	0.084	0.115	0.162	0.240	0.318	0.396	0.474	0.631	0.787	0.943	1.256	1.568	2.350	3.131	3.913	4.694	5.475
44	0.051	0.082	0.112	0.158	0.235	0.311	0.387	0.464	0.616	0.769	0.922	1.227	1.533	2.296	3.050	3.824	4.587	5.351
45	0.050	0.080	0.110	0.155	0.229	0.304	0.379	0.453	0.603	0.752	0.901	1.200	1.499	2.246	2.992	3.739	4.486	5.232
46	0.049	0.078	0.108	0.152	0.225	0.298	0.371	0.444	0.590	0.736	0.882	1.174	1.466	2.197	2.927	3.658	4.388	5.119
47	0.048	0.077	0.106	0.148	0.220	0.291	0.363	0.434	0.577	0.720	0.863	1.149	1.435	2.150	2.865	3.580	4.295	5.010
48	0.047	0.075	0.103	0.145	0.215	0.285	0.355	0.425	0.565	0.705	0.845	1.125	1.405	2.105	2.806	3.506	4.206	4.906
49	0.047	0.074	0.101	0.143	0.211	0.280	0.348	0.417	0.554	0.691	0.828	1.103	1.377	2.063	2.748	3.434	4.120	4.806
50	0.046	0.073	0.100	0.140	0.207	0.274	0.341	0.409	0.543	0.677	0.812	1.081	1.349	2.021	2.694	3.366	4.038	4.710
51	0.045	0.071	0.098	0.137	0.203	0.269	0.335	0.401	0.533	0.664	0.796	1.060	1.323	1.982	2.641	3.300	3.959	4.617
52	0.044	0.070	0.096	0.135	0.199	0.264	0.329	0.393	0.522	0.652	0.781	1.039	1.298	1.944	2.590	3.236	3.882	4.529
53	0.043	0.069	0.094	0.132	0.196	0.259	0.322	0.386	0.513	0.639	0.766	1.020	1.273	1.907	2.541	3.175	3.809	4.443
54	0.043	0.068	0.093	0.130	0.192	0.254	0.317	0.379	0.503	0.628	0.752	1.001	1.250	1.872	2.494	3.117	3.739	4.361
55	0.042	0.067	0.091	0.128	0.189	0.250	0.311	0.372	0.494	0.616	0.739	0.983	1.227	1.838	2.449	3.060	3.671	4.282
56	0.041	0.065	0.089	0.125	0.185	0.245	0.305	0.365	0.485	0.605	0.725	0.965	1.205	1.805	2.406	3.006	3.606	4.206
57	0.041	0.064	0.088	0.123	0.182	0.241	0.300	0.359	0.477	0.595	0.713	0.949	1.184	1.774	2.363	2.953	3.542	4.132
58	0.040	0.063	0.087	0.121	0.179	0.237	0.295	0.353	0.469	0.585	0.701	0.932	1.164	1.743	2.323	2.902	3.481	4.061
59	0.040	0.062	0.085	0.119	0.176	0.233	0.290	0.347	0.461	0.575	0.689	0.917	1.144	1.714	2.283	2.853	3.422	3.992
60	0.039	0.061	0.084	0.117	0.173	0.229	0.285	0.341	0.453	0.565	0.677	0.901	1.125	1.685	2.246	2.806	3.366	3.926
61	0.038	0.061	0.083	0.116	0.171	0.226	0.281	0.336	0.446	0.556	0.666	0.887	1.107	1.658	2.209	2.760	3.310	3.861
62	0.038	0.060	0.081	0.114	0.168	0.222	0.276	0.331	0.439	0.547	0.656	0.873	1.089	1.631	2.173	2.715	3.257	3.799
63	0.037	0.059	0.080	0.112	0.165	0.219	0.272	0.325	0.432	0.539	0.645	0.859	1.072	1.605	2.139	2.672	3.206	3.739
64	0.037	0.058	0.079	0.110	0.163	0.215	0.268	0.320	0.425	0.530	0.635	0.845	1.055	1.580	2.105	2.631	3.156	3.681
65	0.036	0.057	0.078	0.109	0.161	0.212	0.264	0.316	0.419	0.522	0.626	0.833	1.039	1.556	2.073	2.590	3.107	3.624
66	0.036	0.056	0.077	0.107	0.158	0.209	0.260	0.311	0.413	0.515	0.616	0.820	1.024	1.533	2.042	2.551	3.060	3.569
67	0.036	0.056	0.076	0.106	0.156	0.206	0.256	0.306	0.407	0.507	0.607	0.808	1.008	1.510	2.011	2.513	3.014	3.516
68	0.035	0.055	0.075	0.104	0.154	0.203	0.252	0.302	0.401	0.500	0.598	0.796	0.994	1.488	1.982	2.476	2.970	3.464
69	0.035	0.054	0.074	0.103	0.152	0.200	0.249	0.298	0.395	0.492	0.590	0.785	0.979	1.466	1.953	2.440	2.927	3.414
70	0.034	0.053	0.073	0.101	0.149	0.197	0.245	0.293	0.389	0.485	0.581	0.773	0.965	1.445	1.925	2.406	2.886	3.366

EQUATION:  $V = (2.2048 R + 0.0178) \times .3048$  (R = Revolutions per second)

**STANDARD RATING TABLE NO. 2 FOR AA CURRENT METERS (6/99) - VELOCITY IN FEET PER SECOND**

TIME IN SECS	REVOLUTIONS																	
	3	5	7	10	15	20	25	30	40	50	60	80	100	150	200	250	300	350
40	0.183	0.293	0.404	0.569	0.845	1.12	1.40	1.67	2.22	2.77	3.33	4.43	5.53	8.29	11.04	13.80	16.55	19.31
41	0.179	0.287	0.394	0.556	0.824	1.09	1.36	1.63	2.17	2.71	3.24	4.32	5.40	8.08	10.77	13.46	16.15	18.84
42	0.175	0.280	0.385	0.543	0.805	1.07	1.33	1.59	2.12	2.64	3.17	4.22	5.27	7.89	10.52	13.14	15.77	18.39
43	0.172	0.274	0.377	0.531	0.787	1.04	1.30	1.56	2.07	2.58	3.09	4.12	5.15	7.71	10.27	12.84	15.40	17.96
44	0.168	0.268	0.369	0.519	0.769	1.02	1.27	1.52	2.02	2.52	3.02	4.03	5.03	7.53	10.04	12.55	15.05	17.56
45	0.165	0.263	0.361	0.508	0.753	0.998	1.24	1.49	1.98	2.47	2.96	3.94	4.92	7.37	9.82	12.27	14.72	17.17
46	0.162	0.257	0.353	0.497	0.737	0.976	1.22	1.46	1.94	2.41	2.89	3.85	4.81	7.21	9.60	12.00	14.40	16.79
47	0.159	0.252	0.346	0.487	0.721	0.956	1.19	1.43	1.89	2.36	2.83	3.77	4.71	7.05	9.40	11.75	14.09	16.44
48	0.156	0.247	0.339	0.477	0.707	0.936	1.17	1.40	1.86	2.31	2.77	3.69	4.61	6.91	9.20	11.50	13.80	16.09
49	0.153	0.243	0.333	0.468	0.693	0.918	1.14	1.37	1.82	2.27	2.72	3.62	4.52	6.77	9.02	11.27	13.52	15.77
50	0.150	0.238	0.326	0.459	0.679	0.900	1.12	1.34	1.78	2.22	2.66	3.55	4.43	6.63	8.84	11.04	13.25	15.45
51	0.147	0.234	0.320	0.450	0.666	0.882	1.10	1.31	1.75	2.18	2.61	3.48	4.34	6.50	8.66	10.83	12.99	15.15
52	0.145	0.230	0.315	0.442	0.654	0.866	1.08	1.29	1.71	2.14	2.56	3.41	4.26	6.38	8.50	10.62	12.74	14.86
53	0.143	0.226	0.309	0.434	0.642	0.850	1.06	1.27	1.68	2.10	2.51	3.35	4.18	6.26	8.34	10.42	12.50	14.58
54	0.140	0.222	0.304	0.426	0.630	0.834	1.04	1.24	1.65	2.06	2.47	3.28	4.10	6.14	8.18	10.23	12.27	14.31
55	0.138	0.218	0.298	0.419	0.619	0.820	1.02	1.22	1.62	2.02	2.42	3.22	4.03	6.03	8.04	10.04	12.04	14.05
56	0.136	0.215	0.293	0.412	0.608	0.805	1.00	1.20	1.59	1.99	2.38	3.17	3.95	5.92	7.89	9.86	11.83	13.80
57	0.134	0.211	0.289	0.405	0.598	0.791	0.985	1.18	1.57	1.95	2.34	3.11	3.89	5.82	7.75	9.69	11.62	13.56
58	0.132	0.208	0.284	0.398	0.588	0.778	0.968	1.16	1.54	1.92	2.30	3.06	3.82	5.72	7.62	9.52	11.42	13.32
59	0.130	0.205	0.279	0.391	0.578	0.765	0.952	1.14	1.51	1.89	2.26	3.01	3.75	5.62	7.49	9.36	11.23	13.10
60	0.128	0.202	0.275	0.385	0.569	0.753	0.936	1.12	1.49	1.86	2.22	2.96	3.69	5.53	7.37	9.20	11.04	12.88
61	0.126	0.199	0.271	0.379	0.560	0.741	0.921	1.10	1.46	1.83	2.19	2.91	3.63	5.44	7.25	9.05	10.86	12.67
62	0.124	0.196	0.267	0.373	0.551	0.729	0.907	1.08	1.44	1.80	2.15	2.86	3.57	5.35	7.13	8.91	10.69	12.46
63	0.123	0.193	0.263	0.368	0.543	0.718	0.893	1.07	1.42	1.77	2.12	2.82	3.52	5.27	7.02	8.77	10.52	12.27
64	0.121	0.190	0.259	0.362	0.535	0.707	0.879	1.05	1.40	1.74	2.08	2.77	3.46	5.19	6.91	8.63	10.35	12.08
65	0.120	0.187	0.255	0.357	0.527	0.696	0.866	1.04	1.37	1.71	2.05	2.73	3.41	5.11	6.80	8.50	10.19	11.89
66	0.118	0.185	0.252	0.352	0.519	0.686	0.853	1.02	1.35	1.69	2.02	2.69	3.36	5.03	6.70	8.37	10.04	11.71
67	0.117	0.182	0.248	0.347	0.511	0.676	0.840	1.01	1.33	1.66	1.99	2.65	3.31	4.95	6.60	8.24	9.89	11.54
68	0.115	0.180	0.245	0.342	0.504	0.666	0.828	0.991	1.31	1.64	1.96	2.61	3.26	4.88	6.50	8.12	9.74	11.37
69	0.114	0.178	0.241	0.337	0.497	0.657	0.817	0.976	1.30	1.62	1.94	2.57	3.21	4.81	6.41	8.01	9.60	11.20
70	0.112	0.175	0.238	0.333	0.490	0.648	0.805	0.963	1.28	1.59	1.91	2.54	3.17	4.74	6.32	7.89	9.47	11.04

EQUATION:  $V = 2.2048 R + 0.0178$  (R = Revolutions per second)

**INTRODUCTION**

The AA Current Meter is a versatile instrument with a long history of accuracy, reliability, and durability. The precisely balanced Bucket Wheel mounts on a vertical pivot inside a yoke and rotates by water flow. Each rotation of the Bucket Wheel produces an audible click which the user may monitor either manually with a headset or with digital equipment. Separate binding posts on the contact chamber allow users to selectively count either every single rotation or every fifth rotation in fast moving water. Rotation rate is proportional to water velocity. The user compares the number of rotations over a period of time to a rating chart (provided in the back of this manual, and separately with each meter) which determines water velocity. The meter measures streamflow velocities from 0.1 to 25 feet per second (0.03 to 7.6 meters per second).

Users may suspend the meter by a wading rod while wading a stream or by cable from an overhead structure. A tailpiece assembly assures proper meter alignment to water flow when suspended by a cable. Use a Pygmy Current Meter for shallow, slow, wading survey applications.

This manual is by no means exhaustive on the care and use of the AA current meter. However, it provides a firm foundation. For a detailed treatment of different uses of the AA current meter and technical explanations behind water resource investigations, visit <http://pubs.usgs.gov/twri/> which contains nearly all the Techniques of Water-Resources Investigations reports.

**AA Current Meter**

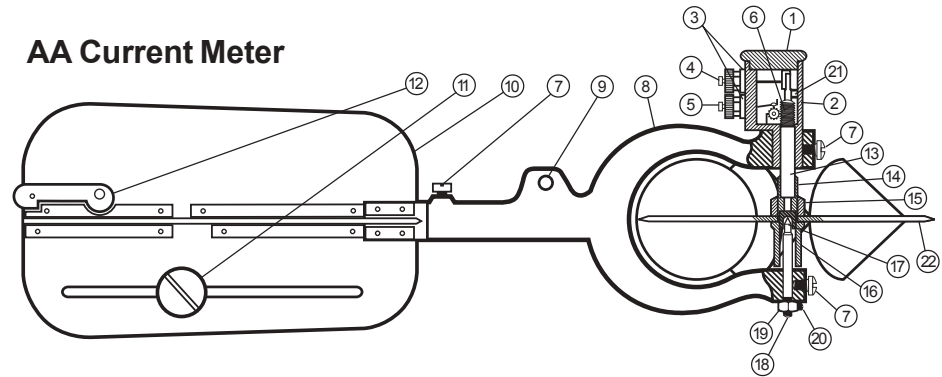

- 1. Contact Chamber Cap
- 2. Contact Chamber
- 3. Binding Post Insulator
- 4. Single-Contact Binding Post
- 5. Penta-Contact Binding Post
- 6. Penta Gear
- 7. Fin Set Screw
- 8. Yoke
- 9. Hanger Screw Hole
- 10. Tail Piece
- 11. Balance Weight
- 12. Fin Lock
- 13. Shaft
- 14. Bucket Wheel Hub
- 15. Bucket Wheel Hub Nut
- 16. Raising Nut
- 17. Pivot Bearing
- 18. Pivot
- 19. Pivot Adjustment Nut
- 20. Pivot Adjustment Nut Set Screw
- 21. Bearing Lug
- 22. Bucket Wheel

## METER ASSEMBLY

1. On the Vertical Fin, lift up on the Locking Tab to clear the Locking Nub from the Locking Hole, and rotate the Locking Tab 180° clockwise.
2. With the Locking Recesses up and on same side as the Locking Tab, slide the Horizontal Fin into the Vertical Fin slot. Guide each fin in between the flanges on the mating fin. This may require a little wiggling.
3. Slide the Horizontal Fin into the Vertical Fin flanges until the curved Locking Recess aligns beneath the Tab Curve.
4. Rotate the Locking Tab 180° counterclockwise until the Locking Nub engages the Locking Hole.
5. Insert the fin assembly Tang fully into the AA Current Meter and tighten the Fin Set Screw. Move the Balance Weight as needed to balance the current meter.

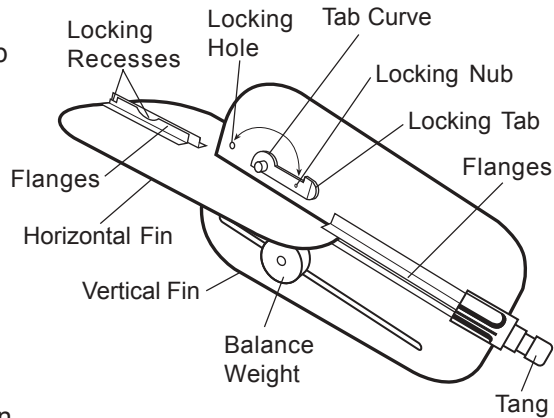

## RECORD KEEPING

Since 1989, investigators maintain current-meter logs to record spin-test data and repairs. Consistent with modern quality-assurance/requirements, current meter logs should include two additional pieces of information: the date of disassembly, cleaning, and inspection (including any significant observations or actions) and the designation stamped on the bucket wheel. This designation is important because some bucket wheels have different performance characteristics than others. Since about 1967, the Bucket Wheel designation consists of the format "S-xx". "S" indicates that the bucket wheel is for a standard rating table. "xx" is the last two digits of the year in which the contract was let for procurement of the bucket wheel (or the meter with which it was assembled). This designation appears under the hub nut on pygmy current meters and cannot be seen unless the meter is disassembled. If a Bucket Wheel has a letter other than S, or no letter designation, consult the OSW to determine if it may be used with a standard rating table.

Enclosed with this manual is a suggested format for the current-meter log to include the new information requirements. A district may use this form or a version modified to meet local needs, or the old form, provided the essential information is recorded. The new meter-log information provides better current meter traceability.

## METER MAINTENANCE

Key to water velocity measurement accuracy is meter maintenance. Clean and adjust the meter often, and repair if necessary.

### Before a Field Trip

1. Remove Pivot and Contact Chamber Cap to clean and lightly oil upper and lower bearing surfaces with Current Meter Oil. Do not use any other type of oil; it may become gummy when exposed to water or make the meter difficult to clean.
2. Examine bearing surfaces for wear or damage, especially Pivot Point. The pivot should feel sharp, not rounded or dull, and with no burr detectable visually or tactilly. Use a magnifying glass for visual inspection.
3. **BINDING POST WIRE:** Replace Pivot if needed and check Binding Post Wire adjustment. Binding Post Wires should touch lightly to minimize drag yet produce a distinct signal. Replace Binding Post Wires with beaded contacts with those without beads. Check Penta-Gear for binding or misalignment.

**MAGHEAD:** Replace Pivot if needed and check magnet strength. Replace Shaft if magnet is weak. Check Reed Switch, located under the binding post, for burn marks on its flat plates caused by too much electrical current passing through the switch. Replace if burn marks are

**MAGHEAD:** If there is a poor or no signal from the meter:

- a. Test shaft magnet strength. A good magnet holds a paper clip firmly. Replace shaft if the paper clip is held weakly or not at all.
- b. Check Reed Switch, located under the binding post, for burn marks on its flat plates caused by too much electrical current passing through the switch. Replace it if burn marks are evident.
- c. Look for corrosion on the Reed Switch wire ends and in its hole in the Contact Chamber. Clean out all corrosion. Use a paper clip to clean corrosion from the Reed Switch hole. To replace Reed Switch, remove Binding Post from Contact Chamber. Remove reed switch keeper spring and Reed Switch. When inserting the new Reed Switch, face its end with the solder ball (sometimes a small disk) toward the binding post. For strongest signals, orient Reed Switch so its flat portions face the meter shaft, with the longer arm facing out from the shaft. Insert keeper spring over the Reed Switch. Replace binding post and tighten until snug.

**18. BINDING POST WIRE:** Oil Shaft and Penta-Gears. Apply one drop of meter oil to the Bearing Lug, the top of the Shaft, and on each side of the Penta-Gear. Apply one or two drops of oil on the Shaft acme threads.

**CAUTION: Too much oil in the Contact Chamber may contaminate Binding Post Wires and make the meter unusable with electronic counters.** Replace Contact Chamber Cap.

**MAGHEAD:** Oil shaft and replace Contact Chamber Cap.

- 19.** Spin test the meter. Conduct all timed spin tests with the meter level, the shaft vertical, and in a location with NO air currents. Setting the meter on its tail fins will NOT level the meter. Minimum spin time is two minutes; optimum is more than four minutes.
- 20.** Using the Raising Nut, lift Bucket Wheel assembly off the Pivot. DO NOT spin Bucket Wheel to engage the Raising Nut; it bends the Shaft.

## STORAGE

Prior to storage, disassemble, inspect, and clean the meter as described previously. If stored less than one year, the meter may be used without further maintenance if inspection and a spin test indicate proper operation. Meters stored longer than one year -- or an indeterminate period -- require cleaning and adjustment as described previously before use.

evident. Look for corrosion on the Reed Switch wire ends and in its hole in the Contact Chamber. Clean out all corrosion. Use a paper clip to clean corrosion from the Reed Switch hole. Clean and replace Reed Switch if corrosion is extensive.

- 4.** Replace Contact Chamber Cap and spin the meter to verify proper operation. The spin need not be timed. Check for rotation difficulty, wobble, or an abrupt stop. If these or some other malfunction or damage is noted, adjust or repair the meter to ensure proper operation before using it.
- 5.** Before each discharge measurement, inspect the meter for damage, fouling, and water on bearing surfaces. Look for milky emulsification of oil and water on the lower bearing and pivot and droplets of water in the Contact Chamber. If water is on the bearing surfaces, dry and re-oil them. Water on these surfaces affects lubricant viscosity and significantly changes meter performance. The lower bearing is more vulnerable to water intrusion.

## After a Field Trip

After a day's use, completely disassemble, inspect, and clean the meter. Repair, if needed. Follow the procedure below.

- 1.** Unscrew Raising Nut by unscrewing nut. NEVER unscrew Raising Nut by holding nut and spinning Bucket Wheel; it bends the Shaft.
- 2.** Remove Contact Chamber Cap. NEVER remove Contact Chamber Cap with Raising Nut engaged; it bends the Shaft.
- 3.** Spin the Bucket Wheel. If it wobbles, determine if the Bucket Wheel Hub also wobbles. If the upper portion of the Bucket Wheel Hub wobbles more than the lower portion, the Shaft is bent. Replace a bent Shaft. A wobbling lower Bucket Wheel Hub indicates a worn Pivot Bearing. Replace Bucket Wheel Hub if Pivot Bearing is worn. If the Bucket Wheel wobbles but the Bucket Wheel Hub does not, the frame is bent. Replace any Bucket Wheel with a bent frame.

To replace the Bucket Wheel, remove the Bucket Wheel Hub Nut to remove the Bucket Wheel. The letter and number on the new Bucket Wheel frame (such as "S90") should face up. Insert the hub alignment pin into the Bucket Wheel frame key slot. This prevents Bucket Wheel slippage on the hub during use. If the alignment pin is missing or damaged, replace the Bucket Wheel Hub.

Individual Bucket Wheel cups can be repaired if not too badly bent. Use a device with a hard, curved edge to work the cup into its original shape. Sometimes, a handle of pliers wrapped in a soft rag works if proper tools are unavailable. If the cup deformity is irreversible, or if plating pops off the base metal, replace the Bucket Wheel.

- 4.** Loosen Contact Chamber set screw and remove Contact Chamber.



5. Remove Pivot and Shaft. To remove Shaft, insert a small Allen wrench into the hole in the Shaft and unscrew it. Clean Shaft and replace it if any portion is bent. Roll Shaft on a flat surface to reveal bent portions.  
  
Replace the Shaft if it is scarred or burred. Scarring on the rounded section of the Shaft indicates sediment in bearing surfaces. Replace the Contact Chamber if this is the case.  
**MAGHEAD ONLY:** If the magnet protrudes and prevents rolling, look for bright sections on the magnet which indicate rubbing on the inner wall of the contact chamber. Replace Shaft if there is rubbing.
6. Clean Pivot and check for burrs on the point with a magnifying glass. Pivot burrs cause inaccuracy. Replace Pivots with burrs or rounded points. Check Pivot for magnetization. Touch the Pivot on a paper clip. If the Pivot lifts the paper clip, it is magnetized. Demagnetize with a bulk magnetic tape eraser or a tape player head demagnetizer, or else replace the Pivot.
7. Clean Pivot Bearing. The end of a cotton swab is usually too large to fit all the way into the Pivot Bearing. Remove some cotton on the sides of the swab and twist the end of the swab into a point to reach the bottom of the Pivot Bearing. A clean Pivot Bearing usually shines. If there is hardened material in the Pivot Bearing, apply a drop or two of meter oil on it for a couple minutes to help remove it. For stubborn material, wrap a small piece of industrial wipe around the end of a small Allen wrench. Take extreme care that the wipe fully covers the wrench end so it scratches neither the Pivot Bearing or its carrier.
8. Clean Contact Chamber. If the Contact Chamber contains no sediment and not much old oil, clean it with a lint-free swab or paper towel covered rod. Sediment or excessive oil in the Contact Chamber may demand a spray cleaning fluid like WD40, which cleans moderately well. Allow all parts to fully dry before reassembly.  
**BINDING POST WIRE ONLY:** Pay particular attention to the bearing surface of the Bearing Lug and the Penta-Gear edges. Sediment or excessive oil in the Contact Chamber may demand Penta-Gear removal and cleaning both it and the chamber with a spray cleaner like WD40. Avoid Penta-Gear removal if possible, but if necessary, remove Binding Post Wires and note Penta-Gear position. Penta-Gear re-installation requires some trial and error adjustment to insure no binding between it and the Shaft. Allow all parts to fully dry before reassembly.
9. Check Yoke with Yoke Alignment Tool (HIF stock number 1101058). The tool should slide easily all the way into the yoke. DO NOT force tool into yoke. DO NOT use the tool to straighten the yoke. To straighten the yoke, use a rubber hammer to gently re-align the yoke arms. Forcing the yoke to move too far weakens it and may crack it.

10. If Pivot Bearing needs replacement, replace the Bucket Wheel Hub, which contains the bearing. Unscrew the Bucket Wheel Hub Nut to remove the Bucket Wheel.
11. Oil Pivot Bearing with only one drop of meter oil; too much oil attracts sediment. Dip the end of a straightened paper clip into meter oil and transfer the drop to the Pivot Bearing. DO NOT use vegetable-based oils, like 3-in-1 oil, which emulsify too easily, or silicon-based oils, which hold sediment and are difficult to clean off.
12. Align Bucket Wheel assembly in the Yoke and thread the Shaft back into the top of the Bucket Wheel Hub using a small Allen wrench. Snug the Shaft, but not so tight that removing it bends the wrench.
13. Insert Pivot through the bottom Yoke hole. Use the Pivot Set Screw to set the Pivot so the Bucket Wheel Hub just touches the lower Yoke arm (this ensures the shaft is not too high during Contact Chamber Cap installation). Adjust Pivot later as needed.
14. Place Contact Chamber over Shaft. DO NOT force Chamber onto Shaft and Yoke. Twist it back and forth if needed to fit it into place. Align marks on front of the Contact Chamber and Yoke or Binding Posts with the back of the Yoke and tighten set screw.
15. While slowly spinning Bucket Wheel, thread Contact Chamber Cap slowly in place making sure it does not bind on the Shaft. The Bucket Wheel stops spinning abruptly if the Shaft hits the Cap.
16. Adjust pivot, if needed
  - a. Verify meter is properly oiled, then invert it with the Pivot up.
  - b. Release Keeper Screw for Pivot Adjustment Nut and unscrew the nut a few turns.
  - c. Release Set Screw and push Pivot inward to eliminate all vertical play of hub assembly.
  - d. Tighten Set Screw temporarily and advance Pivot Adjustment Nut until it touches the Yoke.
  - e. Release Set Screw (not too far, because the pivot should not rotate) and advance the Pivot Adjustment Nut  $\frac{1}{4}$  turn. Then, tighten the Keeper Screw.
  - f. Push Pivot inward as far as possible and tighten Set Screw.
17. **BINDING POST WIRE:** Remove Contact Chamber Cap and set both penta and single count Binding Post Wires for a strong, even click. Oil on a Binding Post Wire or a worn wire degrades contact too much for electronic counters. OSW Hydraulics Laboratory recommends a single count Binding Post Wire contact of about a 30 degree rotational distance and a penta-count Binding Post Wire contact of about a 180 to 270 degree rotational distance for good, clean electronic signals.