

HOBO® Pendant
Event/Temp Data Logger
(Part # UA-003-64)

Inside this package:

- HOBO Pendant Event/Temp Data Logger
- Tie wraps and adhesive mount

Thank you for purchasing a HOBO data logger. With proper care, it will give you years of accurate and reliable measurements.

The HOBO Pendant Event/Temp Data Logger is a rugged, weatherproof event logger with a 10-bit temperature sensor. It is ideal for use with tipping-bucket rain gauges, and can record tens of thousands of measurements and events. The logger uses a coupler and optical base station with USB interface for launching and data readout by a computer.

A base station, coupler, and HOBOWare® software are required for logger operation. Visit www.onsetcomp.com for compatibility information.



Doc # 9831-C, MAN-UA-003
Onset Computer Corporation

Specifications

External event input	
Event sensor	Two-wire interface suitable for measuring mechanical and electrical contact closures
Maximum input frequency	1 Hz (1 pulse per second)
Lockout time	500 ms
Minimum pulse width	1 ms (hardware debounce)
Input/output impedance	100 kΩ
Edge detection	Falling edge, contact closure, or Schmitt-trigger buffer
Preferred switch type	Normally open. For maximum battery life, the event input should be used with its preferred switch type. The logger will work with normally closed switches, but battery life will be compromised.
Open circuit input voltage	Battery voltage; nominally 3.0 V
Maximum input voltage	Battery voltage + 0.3 V
User connection	24 AWG, 2 leads: white (+), black (-)
Temperature measurement	
Measurement range	-20° to 70°C (-4° to 158°F)
Accuracy	± 0.47°C at 25°C (± 0.85°F at 77°F), see Plot A. A solar radiation shield is required for accurate temperature measurements in sunlight.
Resolution	0.10°C at 25°C (0.18°F at 77°F), see Plot A
Drift	Less than 0.1°C/year (0.2°F/year)
Response time	Airflow of 2 m/s (4.4 mph): 10 minutes, typical to 90%
Logger	
Time accuracy	± 1 minute per month at 25°C (77°F), see Plot B
Operating range	-20° to 70°C (-4° to 158°F)
Environmental rating	Tested to NEMA 6 and IP67; suitable for deployment outdoors
Drop specification	1.5 m (5 ft) onto concrete
NIST traceable certification	Available for temperature only at additional charge; temperature range -20° to 70°C (-4° to 158°F)
Battery	CR-2032 3V lithium battery; 1 year typical use
Memory	64K bytes; see "Data storage" on page 3.
Materials	Polypropylene case; stainless steel screws; Buna-N o-ring; PVC cable insulation
Weight	50 g (1.7 oz.)
Dimensions	71 x 33 x 23 mm (2.8 x 1.3 x 0.9 inches); 1.8 m (6 ft) cable
CE	The CE Marking identifies this product as complying with the relevant directives in the European Union (EU).

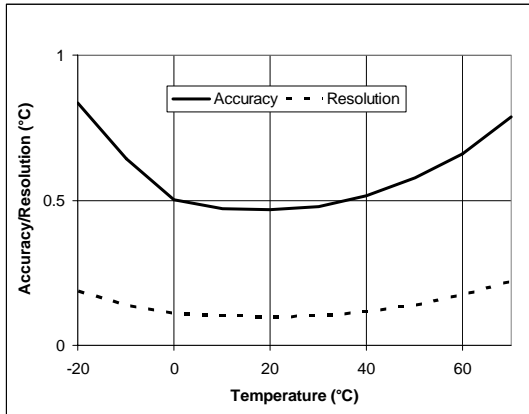

Plot A

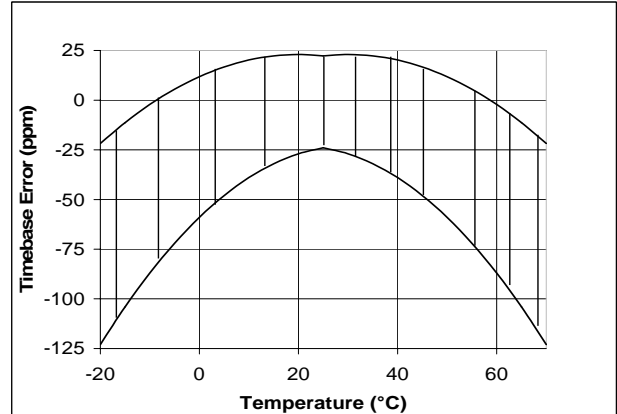

Plot B

Connecting the logger to the computer

The HOBO Pendant logger requires either of the following to connect to the computer:

- Pendant Optic USB Base Station & Coupler (part # BASE-U-1); HOBOWare 2.1 or later

OR

- Optic USB Base Station (part # BASE-U-4) or HOBO Waterproof Shuttle (part # U-DTW-1); coupler (part # COUPLER2-A); HOBOWare 2.2 or later

If possible, avoid connecting at temperatures below 0°C (32°F) or above 50°C (122°F).

1. Plug the USB connector on the base station into an available USB port on your computer.
2. Insert the logger and the base station into the coupler, as shown in the following diagrams.

For BASE-U-1, make sure that the logger is inserted in the end of the coupler that has the magnet, and that the ridges on the base station and logger are aligned with the grooves in the coupler.

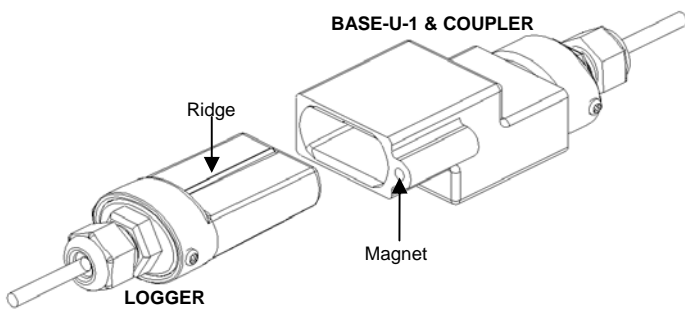

For BASE-U-4 or the HOBO Waterproof Shuttle, firmly insert the optical end of the base station into the D-shaped end of the coupler, and make sure that the ridge on the logger is aligned with the groove in the coupler.

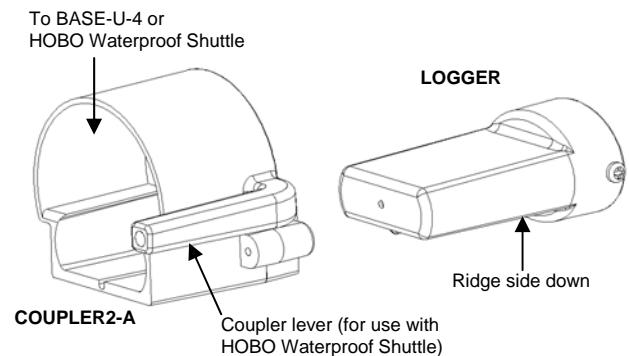

3. If you are using the HOBO Waterproof Shuttle, briefly press the coupler lever to put the shuttle into base station mode.
4. If the logger has never been connected to the computer before, it may take a few seconds for the new hardware to be detected.
5. Use the logger software to launch and read out the logger.

You can read out the logger or check its status while it continues to log, stop it manually with the software, or let it record data until the memory is full. Refer to the software user's guide for complete details on launching, reading out, and viewing data from the logger.

Connecting to a tipping-bucket rain gauge

The logger's black and white input wires can be connected directly to the relay output of most tipping-bucket rain gauges. (Polarity of the input connection is not important.) If your gauge came with a counter display and battery, disconnect these and attach the HOBO Pendant Event/Temp logger instead.

Be careful not to touch the logger's input wires together when connecting or disconnecting the logger while it is logging, as this will record a false event.

Triggered start

This logger can be configured to start at your command, using the magnet in the coupler to trigger a start.

1. Use the logger software to launch the logger with Trigger Start selected. Remove the logger from the coupler.
2. Bring the logger and an empty coupler or strong magnet to the deployment location.

Important: Any magnet can trigger a start. This can be helpful, but it can also cause a premature start. Keep the logger away from strong magnetic fields until you are ready to begin logging.

3. When you are ready for the logger to start logging (for example, after connecting the logger to an external device such as a rain gauge), insert the logger into the empty coupler (or place it next to a strong magnet) and remove it after three seconds. **Important: The logger will not launch if the base station is in the coupler.**
4. Verify that the logger's light is blinking at least every four seconds.

Event logging

The external event channel records the times of transitions from an open contact to a closed contact. The logger checks continuously for transitions. When a transition occurs, it is recorded as an event with a resolution of one second.

The external event channel has a built-in lockout time of 500 milliseconds. The lockout time serves to debounce mechanical switches. To guarantee event capture, the pulse must have a minimum duration of 1 millisecond.

Like other U-Series loggers, this logger stores internal events that are unrelated to the external event inputs. Internal events are stored when the coupler is attached or detached, when the battery drops below approximately 2.7V, when the battery rises above 2.8V, when a host computer is connected, and when the logger is stopped by a command from the host software.

Operation

A light (LED) on the front of the logger confirms logger operation. The following table explains when the light blinks during logger operation.

When:	The light:
The logger is logging	Blinks once every one to four seconds (the shorter the logging interval, the faster the light blinks); blinks when logging a sample
The logger is awaiting a start because it was launched in Start At Interval, Delayed Start, or Trigger Start mode	Blinks once every eight seconds until logging begins

Data storage

The data logger has 64,000 bytes of nonvolatile data storage. Data storage requirements per event are a function of enabled channels and logging interval. When events are three to 12 days apart, 32 bits are required to record a single event (16,000 events). When events are less than 16 seconds apart, only 22 bits are required to record a single event (23,000 events). In most cases, 25,000 to 30,000 data points (including events, temperature, and/or battery measurements) can be logged. For most rain bucket applications, battery life, not memory capacity, will be the factor that limits deployment duration.

Protecting the logger

Do not store the logger in the coupler. Remove the logger from the coupler when you are not using it. When the logger is in the coupler or near a magnet, it consumes more power and will drain the battery prematurely.

Keep the logger away from magnets. Being near a magnet can cause false coupler events to be logged. It can also launch the logger prematurely if it was waiting for a trigger start.

If the logger is used in a humid location, periodically inspect the desiccant and dry it if it is not bright blue. To dry the desiccant, remove the desiccant pack and leave the pack in a warm, dry location until the bright blue color is restored. (Refer to the "Battery" section for instructions on removing and replacing the logger cap.)

Temperature range	Desiccant maintenance schedule
Less than 30°C (86°F)	Approximately once per year
30° to 40°C (86° to 104°F)	Approximately every six months
Over 40°C (104°F)	Approximately every three months

Note! Static electricity may cause the logger to stop logging.

To avoid electrostatic discharge, transport the logger in an anti-static bag, and ground yourself by touching an unpainted metal surface before handling the logger. For more information about electrostatic discharge, visit <http://www.onsetcomp.com/support/support.html>.

Battery

The logger requires one 3-Volt CR-2032 lithium battery. Battery life varies based on the temperature, the type of external switch, and the frequency at which the logger is recording data (the logging interval). A new battery typically lasts one year with logging intervals greater than one minute. Deployments in extremely cold or hot temperatures, or logging intervals faster than one minute, may significantly reduce battery life. Continuous logging at the fastest logging rate of one second will deplete the battery in as little as two weeks.

To replace the battery:

1. Remove the two screws that secure the end cap to the case and remove the cap. The circuit board is attached to the cap.

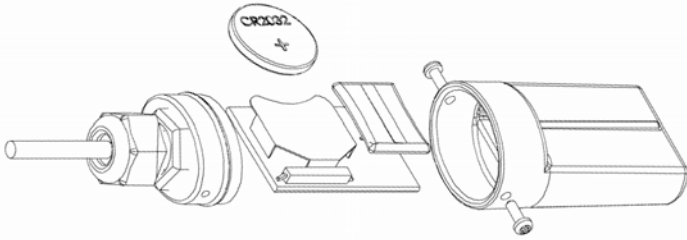

2. Examine the desiccant pack that is tucked below the battery holder. If the desiccant is not bright blue, put the desiccant pack in a warm, dry place until the blue color is restored.
3. Carefully push the battery out of the holder with a small, nonmetallic blunt instrument.
4. Insert a new battery, positive side facing up.
5. Return the circuit board, desiccant pack, and label to the case, carefully aligning the circuit board with the grooves in the case so that the battery faces the ridged side of the case.
6. Replace the end cap, ensuring that the o-ring is seated in the groove, and not pinched or twisted. Make sure no dirt or lint is trapped on the o-ring, as this could result in a leak.
7. Re-fasten the screws. Do not over-tighten the screws.

⚠ WARNING: Do not cut open, incinerate, heat above 85°C (185°F), or recharge the lithium battery. The battery may explode if the logger is exposed to extreme heat or conditions that could damage or destroy the battery case. Do not dispose of the logger or battery in fire. Do not expose the contents of the battery to water. Dispose of the battery according to local regulations for lithium batteries.

Service and Support

As part of Onset's ongoing efforts to provide 100% customer satisfaction, our Continuing Engineering Group constantly monitors and evaluates all of our products and software. In the unlikely event any significant defect is found, Onset will notify you. If you find a defect, please e-mail us at loggerhelp@onsetcomp.com.

HOBO products are easy to use and reliable. In the unlikely event that you have a problem with this instrument, contact the company where you bought the logger: Onset or an Onset Authorized Dealer. Before calling, you can evaluate and often solve the problem if you write down the events that led to the problem (are you doing anything differently?) and if you visit the Technical Support section of the Onset web site at www.onsetcomp.com/support.html. When contacting Onset, ask for technical support and be prepared to provide the product number and serial number for the logger and software version in question. Also completely describe the problem or question. The more information you provide, the faster and more accurately we will be able to respond.

Onset Computer Corporation
470 MacArthur Blvd., Bourne, MA 02532
Mailing: PO Box 3450, Pocasset, MA 02559-3450
Phone: 1-800-LOGGERS (1-800-564-4377) or 508-759-9500
Fax: 508-759-9100
E-mail: loggerhelp@onsetcomp.com
Internet: www.onsetcomp.com

Warranty

Onset Computer Corporation (Onset) warrants to the original end-user purchaser for a period of **one year** from the date of original purchase that the HOBOb® product(s) purchased will be free from defect in material and workmanship. During the warranty period Onset will, at its option, either repair or replace products that prove to be defective in material or workmanship. This warranty shall terminate and be of no further effect at the time the product is (1) damaged by extraneous cause such as fire, water, lightning, etc. or not maintained in accordance with the accompanying documentation; (2) modified; (3) improperly installed; (4) repaired by someone other than Onset; or (5) used in a manner or purpose for which the product was not intended.

THERE ARE NO WARRANTIES BEYOND THE EXPRESSED WARRANTY ABOVE. IN NO EVENT SHALL ONSET BE LIABLE FOR LOSS OF PROFITS OR INDIRECT, CONSEQUENTIAL, INCIDENTAL, SPECIAL OR OTHER SIMILAR DAMAGES ARISING OUT OF ANY BREACH OF THIS CONTRACT OR OBLIGATIONS UNDER THIS CONTRACT, INCLUDING BREACH OF WARRANTY, NEGLIGENCE, STRICT LIABILITY, OR ANY OTHER LEGAL THEORY.

Limitation of Liability. The Purchaser's sole remedy and the limit of Onset's liability for any loss whatsoever shall not exceed the Purchaser's price of the product(s). The determination of suitability of products to the specific needs of the Purchaser is solely the Purchaser's responsibility.

THERE ARE NO WARRANTIES BEYOND THE EXPRESSED WARRANTY OFFERED WITH THIS PRODUCT. EXCEPT AS SPECIFICALLY PROVIDED IN THIS DOCUMENT, THERE ARE NO OTHER WARRANTIES EXPRESS OR IMPLIED, INCLUDING BUT NOT LIMITED TO, ANY IMPLIED

WARRANTIES OF MERCHANTABILITY OR FITNESS FOR A PARTICULAR PURPOSE. NO INFORMATION OR ADVICE GIVEN BY ONSET, ITS AGENTS OR EMPLOYEES SHALL CREATE A WARRANTY OR IN ANY WAY INCREASE THE SCOPE OF THE EXPRESSED WARRANTY OFFERED WITH THIS PRODUCT.

Indemnification. Products supplied by Onset are not designed, intended, or authorized for use as components intended for surgical implant or ingestion into the body or other applications involving life-support, or for any application in which the failure of the Onset-supplied product could create or contribute to a situation where personal injury or death may occur. Products supplied by Onset are not designed, intended, or authorized for use in or with any nuclear installation or activity. Products supplied by Onset are not designed, intended, or authorized for use in any aeronautical or related application. Should any Onset-supplied product or equipment be used in any application involving surgical implant or ingestion, life-support, or where failure of the product could lead to personal injury or death, or should any Onset-supplied product or equipment be used in or with any nuclear installation or activity, or in or with any aeronautical or related application or activity, Purchaser will indemnify Onset and hold Onset harmless from any liability or damage whatsoever arising out of the use of the product and/or equipment in such manner.

Returns

Please direct all warranty claims and repair requests to place of purchase.

Before returning a failed unit directly to Onset, you must obtain a Return Merchandise Authorization (RMA) number from Onset. You must provide proof that you purchased the Onset product(s) directly from Onset (purchase order number or Onset invoice number). Onset will issue an RMA number that is valid for 30 days. You must ship the product(s), properly packaged against further damage, to Onset (at your expense) with the RMA number marked clearly on the outside of the package. Onset is not responsible for any package that is returned without a valid RMA number or for the loss of the package by any shipping company. Loggers must be clean before they are sent back to Onset or they may be returned to you.

Repair Policy

Products that are returned after the warranty period or are damaged by the customer as specified in the warranty provisions can be returned to Onset with a valid RMA number for evaluation.

ASAP Repair Policy. For an additional charge, Onset will expedite the repair of a returned product.

Data-back™ Service. HOBOb data loggers store data in nonvolatile EEPROM memory. Onset will, if possible, recover your data.

Tune Up Service. Onset will examine and retest any HOBOb data logger.

© 2005, 2006 Onset Computer Corporation. All rights reserved.
Part #: MAN-UA-003, Doc #: 9831-C, Patent #: 6,826,664

Onset, HOBOb, and HOBObware are registered trademarks of Onset Computer Corporation. Other products and brand names may be trademarks or registered trademarks of their respective owners.