

Technical Bulletin M0006

▲ Keep this sheet for your records.

Field King™ Deluxe and D.B. Smith Relax™ Backpack Sprayers

No. 13398

Field King Deluxe, 4 gal.

No. 13399

Field King Deluxe, 5 gal.

No. 13434

D.B. Smith Relax, 4 gal.



Field King Deluxe and D.B. Smith Relax Backpack Sprayers

Field King Deluxe

Positive, palm-activated trigger with lock and grip and an in-line poly filter to protect the trigger and nozzle from clogs. Features quality Viton® gaskets and seals; 24" long brass spray wand with a 50" reinforced hose; fully adjustable brass nozzle which produces a straight stream to fine mist plus a fan spray nozzle for a wide spray pattern; wide-fill opening with basket screen in top of tank; a pump handle which mounts on either side for left- or right-handed operation and locks upright for easy storage; removable pump assembly; convenient carry handle with a built-in wand storage clip; dual paddle agitators mix contents each time you pump; molded lumbar support; waist belt and adjustable padded shoulder straps; and a compact design with a low center of gravity.

D.B. Smith Relax

Foam nozzle eliminates drift by producing visible, heavy droplets which are more wind-resistant and allow you to see exactly where chemical is being applied. Features a 4-gallon, high density polyethylene tank with molded graduations, Viton® O-rings, 24" curved extension wand, fully adjustable brass nozzle, padded shutoff grip, 80° flat fan nozzle, left- or right-handed pump handle mounts, adjustable padded straps, dual paddle agitators keep chemicals mixed, in-line filter at shutoff to prevent clogging, full lumbar support, 56" reinforced hose, and a convenient carry handle. The Relax Backpack Sprayer is approved and recommended for the application of Roundup®.

Tech Support 800-430-5566

If you need more information or would like advice from an experienced professional, call our Technical Support team.

Sales 800-647-5368

Our sales department will gladly fax you an order form, update you on pricing, or take your order over the phone.

Online www.forestry-suppliers.com

For credit card and open account orders, visit our web site to place your order.



▲ Keep this sheet for your records.

Field King Deluxe and D.B. Smith Relax Backpack Sprayers

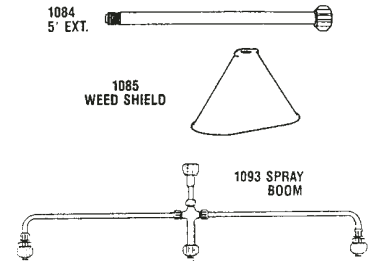
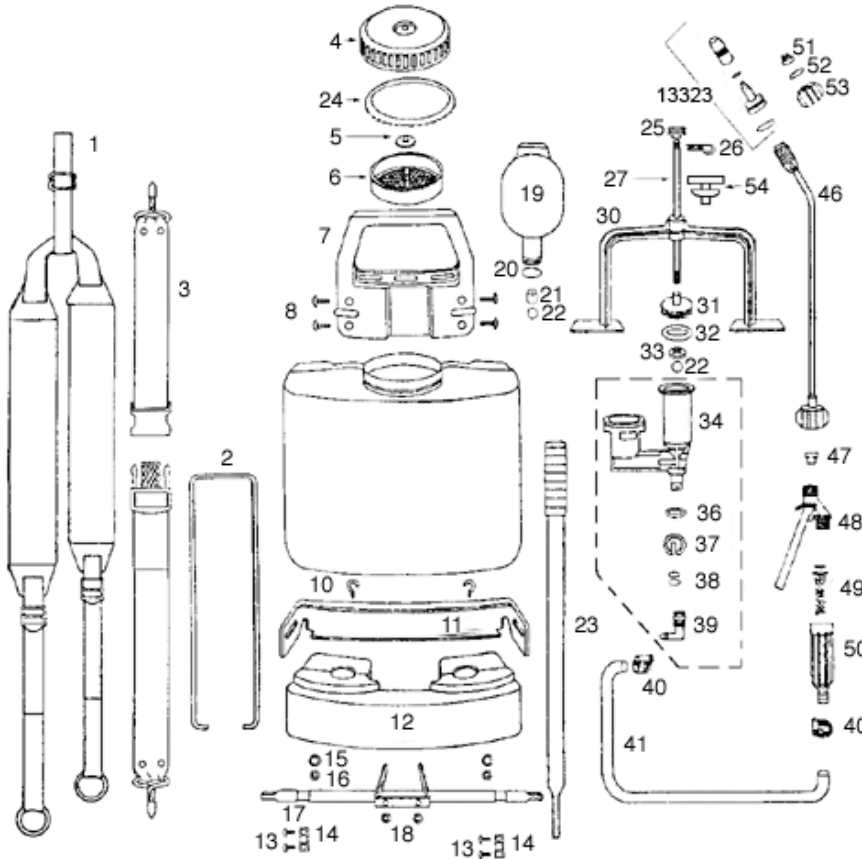

Field King/Relax Accessories & Kits

Dia. No.	Stock No.	Description
1084	13374	5' Lance Extension
1085	13375	Weed Shield
1093	13376	3 Nozzle Spray Boom, 30"
	13323	Adjustable Brass Nozzle Assembly
	13381	Fan Spray Nozzle Assembly
	13553	O-Ring Kit: Incl. 20, 32, 38 (2)
	13569	Replacement Foam Nozzle
	13597	Replacement Reservoir with Bladder

Dia. No.	Stock No.	Description
1	13377	Strap (Padded)
2	13489	Connector Rod for 4 gal. short tank, 13.5"
2	13490	Connector Rod for 5 gal. short tank, 16"
2	13644	Connector Rod for 4 gal. tall tank, 14.75"
2	13645	Connector Rod for 5 gal. tall tank, 17.25"
3	13378	Waist Belt
4	13491	Fill Cap
5	13492	Check Valve
6	13493	Strainer Basket
7	13494	Carry Handle
8	13495	Screw for Handle (4 req.)
10	13499	Hook Bolt (2 req.)
11	13379	Lumbar Support
12	13500	Base
13	13501	Screw (4 req.)
14	13502	Retainer Bracket (2 req.)
15	13503	Washer (2 req.)
16	13504	Lock Nut (2 req.)
18	13506	Push Nut (2 req.)
19	13507	Reservoir

Dia. No.	Stock No.	Description
19	13597	Reservoir w/bladder for D.B. Smith Relax Backpack Sprayer
20	13508	Reservoir O-Ring
21	13509	Check Cap (Manifold)
22	13510	Check Ball (Used in Manifold & Pump - 2 req.)
23	13511	Pump Handle Assembly
24	13402	Cover Gasket
25	13513	Pivot
27	13515	Plunger Rod Assy. for 8.25" short 4 gal. tank. Incl. Rod, 31, 32
27	13516	Plunger Rod Assy. for 10.75" short 5 gal. tank. Incl. Rod, 31, 32
27	13646	Plunger Rod Assy. for 9.5" tall 4 gal. tank. Incl. Rod, 31, 32
27	13647	Plunger Rod Assy. for 12" tall 5 gal. tank. Incl. Rod, 31, 32
30	13344	Agitator
31	13519	Piston
32	13520	O-Ring (for Piston)

Dia. No.	Stock No.	Description
33	13521	Check Can (for Pump)
34	13590	Complete Pump Assembly
36	13591	O-Ring (for Pump)
37	13592	Hose Fitting Nut
39	13594	Pump Fitting Assy. w/O-rings
40	13528	Gear Clamp (2 req.)
41	13529	Hose, 56"
46	13322	19" Aluminum Curved Ext.
47	13536	Valve Seat
48	13537	Shutoff Assy. Viton® Seal
49	13538	Filter
50	13539	Handle
	13570	Threaded Handle for Pressure Regulator
51	13540	Fan Spray, Tip Only
52	13541	O-Ring
53	13315	Cap Nut
54	13403	Rod Seal Grommet