

SS-10 ELECTRONIC INTERFACE INSTALLATION INSTRUCTIONS

The SS-10 is designed to work with most vehicles that are equipped with non-mechanical transmission sensors (no speedometer cable). This interface amplifies and conditions pulses emitted from your vehicle's speed sensor and supplies the signal to your QTT DMI to accurately compute traveled distances.

! IMPORTANT ! The SS-10 is an intelligent design. Sensitivity level, division factor and diagnostics are controlled by six momentary push buttons. Two seven segment LEDs display the sensitivity and divisor settings. When power is initially applied to the SS-10, the factory default settings are displayed for 5 seconds. When the LEDs are on, the SS-10 is in "Adjust Mode". When in Adjust Mode, the user can change the default settings and execute diagnostics. The SS-10 will stay in Adjust Mode until the user has not pressed a push button for 5 seconds. The LEDs will then be turned off and 2 seconds later, the SS-10 will enter "Run Mode". Run Mode is the normal mode for operation. When you need to make an adjustment or execute diagnostics, press and release any push button (SW1-SW6). The SS-10 will enter Adjust Mode and the LEDs will display the current settings. It is important to note that when in Adjust Mode, the SS-10 will NOT produce an output for the DMI. Changes to sensitivity and divisor do NOT take effect until the SS-10 is in Run Mode (2 seconds after LEDs are off).

! CAUTION ! Failure to disconnect the positive battery lead may cause damage to the sensor and related components. (this does not apply to the optional Power Adapter Cable)

STEP 1: Disconnect the positive battery terminal.

STEP 2: Two cable assemblies are required to connect the sensor. One is called a split cable and consists of two separate cables. The split cable assembly contains one 15 ft. cable and one 10 ft. cable. The 10 ft. cable has a black and red wire. Connect the red wire to the positive battery terminal. Connect the black wire to the negative battery terminal. Refer to FIGURE 1 for more information.

STEP 3: The 15 ft. cable mentioned in STEP 2 above will be connected to a wire from your transmission, engine control module or differential depending on the vehicle model & year. **Note: The connection should be made using wire-to wire solder.**

WE DO NOT RECOMMEND A "QUICK CRIMP" CONNECTOR.

STEP 4: Route the remaining cable assembly to the DMI. Connect the modular phone jack to the DMI receptacle labeled "POWER".

STEP 5: The SS-10 has two cables exiting the plastic enclosure. The label affixed to the bottom side of the enclosure depicts the cable signals. Each cable has a connector attached. One connector is an inline four (4) pin style and one is a dual row four (4) pin style. These connectors are keyed such that they cannot be reversed. Attach each connector to the respective mate of each cable assembly.

STEP 6: Connect the positive battery terminal. Turn on the DMI to verify the battery connections. If the DMI will not power on, check your connections at the battery, speed sensor and DMI.

STEP 7: The SS-10 speed sensor has adjustable sensitivity. The device is shipped with a setting that is appropriate for most vehicles. Start the engine, power on the DMI and press the "RUN/HOLD" button to enter run mode. The DMI should NOT count while the vehicle is stationary. If you notice counting you will have to reduce the sensitivity. Refer to FIGURE 3 and Troubleshooting Guide 2 for more information.

STEP 8: Start driving, the DMI should start counting. If the DMI does not count or only counts at higher speeds, you will need to increase the sensitivity. When the sensitivity is set properly, the DMI will count at very low speeds (less than 1MPH) and never count erroneously. Some vehicles do not generate a signal at extremely low speeds. This is inherent to the vehicle model and connection (Engine Control Module). Transmission connections generally produce a signal at very low speeds. Refer to FIGURE 3 and Troubleshooting Guide 1 for more information.

STEP 9: A small percentage of vehicles may register false counting after driving and coming to a stop. Decrease sensitivity if you notice this symptom. Refer to FIGURE 3 and Troubleshooting Guide 2 for more information.

STEP 10: Follow the calibration procedure outlined in the manual. You should have a calibration number between 400 & 1400. The ideal calibration number should be as close to 1000 as possible. The calibration number will appear in the far right-hand window at the end of the calibration procedure. If the calibration number is less than 400, increase the divisor. If the calibration number is greater than 1400, decrease the divisor. The SS-10 speed sensor is shipped with a divisor equal to one, but is adjustable to suit virtually all vehicle installations. Refer to FIGURE 3 for more information.

STEP 11: Once the calibration is complete, you may want to seal the SS-10 enclosure with silicon sealant to prevent corrosion or water damage to the components inside.

! IMPORTANT ! Sensitivity adjustments do not take effect until the SS-10 is in Run Mode (2 seconds after the LEDs are off).

TROUBLESHOOTING GUIDES

Follow these simple steps to resolve a problem with your equipment or your installation. There are basically three types of problems that are encountered by customers during installations and are addressed in the following steps. Please refer to your specific problem by answering the following questions:

1. Does your DMI power up and seem to work, but will not count at all? (If YES, Refer to **GUIDE 1**)
2. Does your DMI count all the time or at any time you feel it should not be counting? (If YES, refer to **GUIDE 2**)
3. Does your DMI display AECs (Automatic Error Correction)? (If YES, refer to **GUIDE 2**)
4. Does your DMI seem to be counting just fine but it is not accurate enough? (If YES, Refer to **GUIDE 3**)
5. Does your DMI have a problem involving the MPH displayed? (If YES, Refer to **GUIDE 3**)

TROUBLESHOOTING GUIDE 1

If your DMI seems to be working correctly, but will not count at all, this could be a very easy problem to correct. Follow these simple steps to determine what the problem may be. Be sure to retest your DMI after each step or if the trouble is found. Increasing sensitivity beyond that which is required may result in erroneous counting. If for some reason you change the sensitivity and the problem is resolved through other means, you may need to decrease sensitivity to prevent erroneous counting. The factory default setting of "3" will work in most vehicles.

STEP 1: If a splice clip or quick connector clip was used in the installation, re-splice the wire or solder the wire in.

You may not be getting a good connection.

STEP 2: Recheck all the wiring (**FIGURE 1** on page 4).

STEP 3: Check the calibration number in the DMI so that it is not set to zero. To check the calibration number, simply turn the DMI on and press the **1CAL** key. The display should read "**CAR1**" followed by a number. If that number is zero, type 1000 and press **MARK/ENTER**.

STEP 4: To increase sensitivity, follow these steps:

- a) Put the SS-10 in Adjust Mode (to enter Adjust Mode, press and release any push button SW1- SW6).
- b) Once the current settings are displayed, press and release SW1. The LED value for sensitivity will increment.
- c) 2 seconds after the LEDs are off the SS-10 will enter Run Mode.
- d) When in Run Mode, start driving to see if the DMI will count. If not, repeat these steps until the DMI starts counting.
- e) If you increased sensitivity to the maximum setting of "9" and the DMI is still not counting, you should set the sensitivity setting back to the factory default of "3". Leaving the sensitivity setting at maximum may result in erroneous counting once the problem is resolved.

STEP 5: At this point, you will want to do a "tap test" on the Nu-Metrics equipment. To do this, power on the DMI and make sure the DMI is in "RUN" mode. To perform a "TAP" test, the SS-10 must be in Adjust Mode (to enter Adjust Mode, press and release any push button SW1- SW6). When the LEDs are on, press and hold SW6 until the LEDs rotate clockwise. The DMI should count for 10 seconds. This test verifies that the connection from the SS-10 to the DMI is correct. Next, you'll need to perform a sensor test. To do this, the SS-10 must be in Adjust Mode. Press and hold SW3 until the LEDs rotate counterclockwise. The DMI should count for 10 seconds. This test verifies that the SS-10 electronics are operating properly.

STEP 6: If none of the above steps have fixed the problem, the possibility exists that your vehicle's speed sensor wires have been swapped, you have not interfaced to the sensor properly or the sensor is not receiving a signal from the vehicle speed sensor. Call the service department for additional help at (724) 438-8750. Monday - Friday; 8 am to 5pm EST.

TROUBLESHOOTING GUIDE 2

If your DMI is counting at an undesired time or all the time, engine noise or electrical interference may be causing the problem.

Depending on vehicle model and connection, adjusting the SS-10 sensitivity may be necessary. Ideally, the sensitivity adjustment is such that the DMI counts at very low speeds and never counts erroneously. Counting at idle, after stopping or erratic counting while driving (which the DMI would display as AEC) are examples of the sensitivity being too high. Rerouting cables and/or lowering sensitivity should resolve the problem.

! IMPORTANT ! If you did not hook up the positive & negative leads directly to the battery it may lead to this problem. Check that the power cable and sensor cable are not touching or coiled together. This can result in interference.

To correct this problem perform the following steps:

STEP 1: Ensure that all wiring is as far away from the vehicle's electrical components as possible. This could include the coil, plug wires, alternator, etc. Ensure there is separation between the power cable and the sensor cable. Do not coil excess cables together.

STEP 2: To decrease sensitivity, follow these steps:

- a) Put the SS-10 in Adjust Mode (to enter Adjust Mode, press and release any push button SW1- SW6).
- b) Once the current settings are displayed, press and release SW2. The LED value for sensitivity will decrement.
- c) 2 seconds after the LEDs are off, the SS-10 will enter Run Mode.
- d) If the DMI still counts erroneously, repeat these steps until the DMI counts accurately.

STEP 3: If you reach the minimum sensitivity setting of "0", Contact the Nu-Metrics service department at (724) 438-8750 Monday-Friday, 8:00-5:00 EST.

TROUBLESHOOTING GUIDE 3

If your DMI is having these types of problems it may be due to an improper calibration of the DMI. Please refer to the calibration instructions in the Nitestar manual.

DISCLAIMER: QTT electronic interface adapters are sold with the understanding that they will be installed by a professional installer who has the required expertise and supporting documentation such as Mitchell or Motor electrical service manuals or equivalent. Any documentation or information provided by QTT is a general guideline for reference and is supplied without warranty or liability of any kind. Since the conditions or methods of installation, operation, use and maintenance of this equipment are beyond its' control, QTT does not assume responsibility and expressly disclaims liability of loss, damage, or expense of any kind arising out of or in any way connected with any installation, operation, or maintenance of this sensor. The user who attempts to install the electronic interface adapter assumes all responsibility for problems caused by incorrect or improper installation.

Quixote
Transportation Technologies, Inc.

nu-metrics[®]

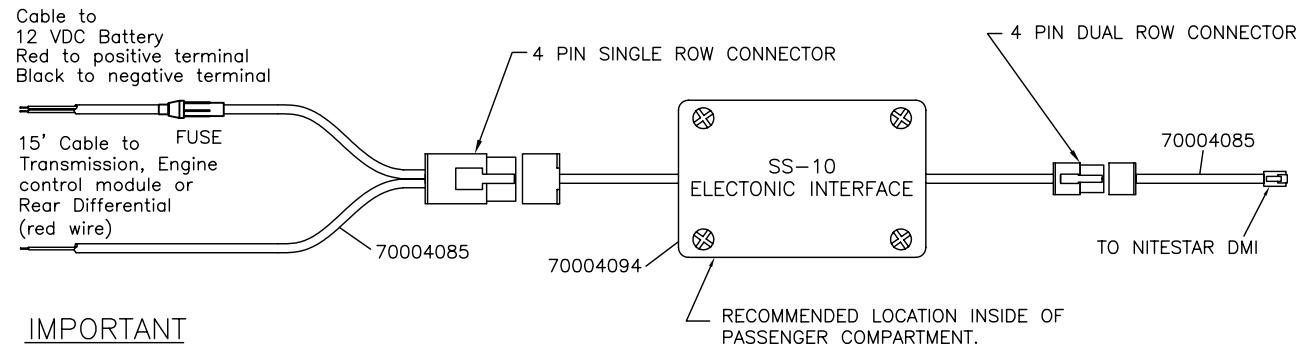

IMPORTANT

Ensure there is separation between these cables along the entire length. Coil the excess from each cable separately and secure to prevent the cables from touching. Applies to 70004085 and 70004086.

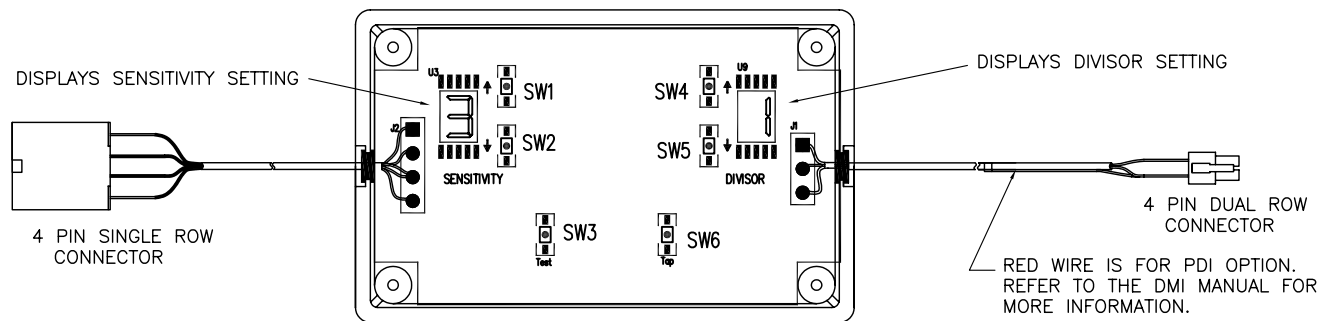
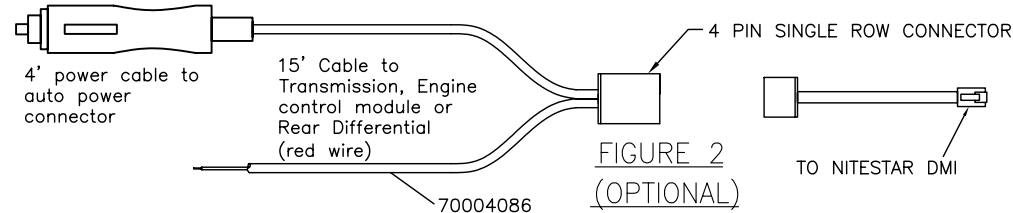

ADJUST MODE = LEDS ON
 RUN MODE = LEDS OFF

- BEFORE YOU CAN MAKE ADJUSTMENTS OR EXECUTE DIAGNOSTICS, THE SS-10 MUST BE IN "ADJUST MODE". THE SS-10 WILL NOT PRODUCE AN OUTPUT TO THE DMI WHEN IN ADJUST MODE.
 - TO ENTER ADJUST MODE, PRESS AND RELEASE ANY PUSH BUTTON (SW1-SW6). THE LEDS WILL DISPLAY THE CURRENT SETTINGS. YOU CAN NOW CHANGE SENSITIVITY, DIVISOR OR EXECUTE DIAGNOSTICS.
 - AFTER YOU ARE FINISHED MAKING ADJUSTMENTS OR EXECUTING DIAGNOSTICS, THE LEDS WILL TURN OFF AFTER FIVE SECONDS AND THE SS-10 WILL ENTER "RUN MODE".
- ! IMPORTANT !** THE SS-10 WILL NOT PRODUCE AN OUTPUT UNTIL TWO SECONDS AFTER THE LEDS ARE TURNED OFF.

SWITCH DESCRIPTIONS	
SW1	- INCREASE SENSITIVITY
SW2	- DECREASE SENSITIVITY
SW3	- SENSOR TEST
SW4	- INCREASE DIVISOR
SW5	- DECREASE DIVISOR
SW6	- TAP TEST

DIVISOR SETTINGS		
VALUE	=	DIVISION FACTOR
1	=	1 to 1
2	=	1 to 2
3	=	1 to 3
4	=	1 to 4
5	=	1 to 6
6	=	1 to 8
7	=	1 to 16
8	=	1 to 32
9	=	1 to 64

FIGURE 3

NOTES:

THE IDEAL CALIBRATION NUMBER SHOULD BE AS CLOSE TO 1000 AS POSSIBLE.
 IF THE CALIBRATION NUMBER DISPLAYED ON THE DMI IS LESS THAN 400, INCREASE THE DIVISOR VALUE.
 IF THE CALIBRATION NUMBER IS GREATER THAN 1400, DECREASE THE DIVISOR VALUE.
CALIBRATION # EXAMPLE
 IF THE INITIAL CALIBRATION IS 50 (AS DISPLAYED ON THE NITESTAR)
 USE VALUE SETTING #7 (1 TO 16) ON THE DIVISOR LED.
 THE NEW CALIBRATION # SHOULD BE APPROXIMATELY 800 (16 X 50 = 800) AFTER RECALIBRATING THE UNIT.

P/N REFERENCE GUIDE

70004094	SS-10 ELECTRONIC INTERFACE
70004085	STANDARD CABLE KIT (INCLUDES SENSOR TO NS AND SENSOR TO VEHICLE "STANDARD" CABLES)
70004086	OPTIONAL POWER ADAPTER CABLE KIT - POWER PLUG

CONNECTION WIRING

	YEAR	MAKE	MODEL	LOCATION	WIRE COLOR
1	2000-07	GM/GMC	TRUCK	B	PPL/WHT
2	2000-07	GM/GMC	TRUCK	D	YEL/BLK
3	2007	GM	COLORADO	B	YELLOW
4	2004-06	GM	COLORADO	B	YELLOW
5	2004-06	GM	COLORADO	A	YEL/BLK
6	2006-07	GM	CARS	B	YELLOW OR ORANGE
7	2000-05	GM	CARS	B	YELLOW
8	2000-05	GM	CARS	A	DARK GREEN
9	2008	FORD	TRUCK	B	YEL/ORG
10	2008	FORD	TRUCK	A	YEL/BLU
11	2000-07	FORD	TRUCK	B	DRK BLU/YEL
12	2000-07	FORD	TRUCK	A	GRY/BLK
13	2000-06	FORD	TRUCK	C	RED/PINK or GRN/RED
14	2003-06	FORD	CROWN VIC	B	DRK BLU/YEL
15	2003-06	FORD	CROWN VIC	A	GRY/BLK
16	2004-06	DODGE	TRUCK	B	GRN/BRN
17	2004-06	DODGE	TRUCK	A	GRN/YEL
18	2000-03	DODGE	TRUCK	B	BLU/BLK
19	2000-03	DODGE	TRUCK	A	WHITE/ORG
20	2004-08	DODGE	DURANGO	B	DK GRN/BRN
21	2000-03	DODGE	DURANGO	A	WHITE/ORG
22	2005-06	DODGE	STRATUS	B	LT GRN/WHITE
23	2007	TOYOTA	TACOMA	B	RED/YEL
24	2005-06	TOYOTA	TACOMA	B	GREEN
25	2005-06	TOYOTA	TACOMA	A	VIOLET/WHT

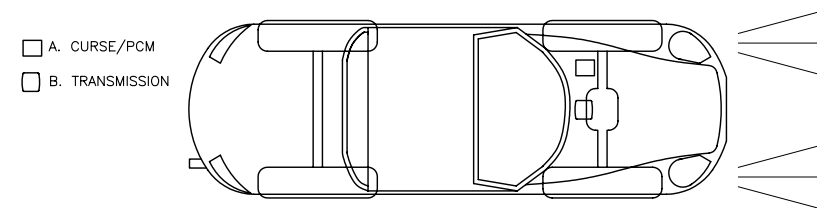

DIAGRAM 1 FRONT WHEEL DRIVE

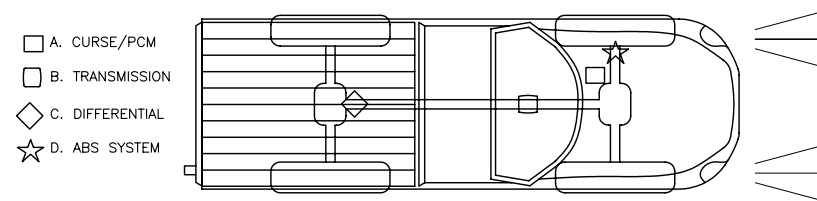

DIAGRAM 2 2/4 WHEEL DRIVE

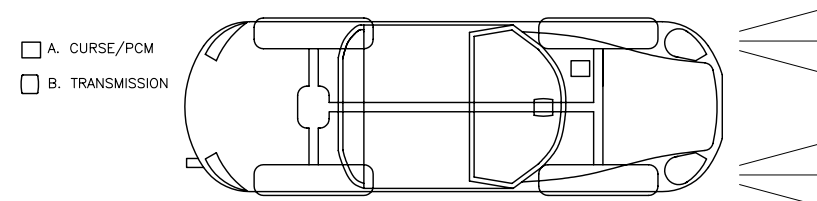

DIAGRAM 3 REAR WHEEL DRIVE