

OWNER'S MANUAL

Model: LG-3025 (5301267)

(25 Gallon Lawn & Garden/ATV Boomless Sprayer)

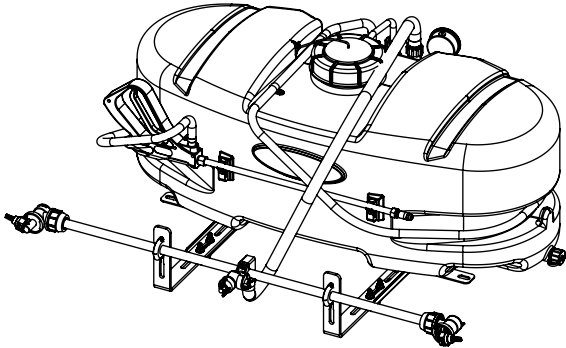

BEFORE RETURNING THIS PRODUCT
FOR ANY REASON, PLEASE CALL

1-800-831-0027

IF YOU SHOULD HAVE A QUESTION OR
EXPERIENCE A PROBLEM WITH YOUR
FIMCO INDUSTRIES PRODUCT:

1-800-831-0027

BEFORE YOU CALL, PLEASE HAVE THE
FOLLOWING INFORMATION AVAILABLE:
SALES RECEIPT & MODEL NUMBER. IN MOST
CASES, A FIMCO INDUSTRIES EMPLOYEE CAN
RESOLVE THE PROBLEM OVER THE PHONE.

General Information

Thank you for purchasing this FIMCO product. The purpose of this manual is to assist you in operating and maintaining your lawn & garden/ATV sprayer. Please read it carefully, as it furnishes information which will help you achieve years of trouble-free operation.

Warranty/Parts/Service

Products are warranted for one year from date of purchase against manufacturer or workmanship defects.

Commercial users have a 90 day warranty.

Your authorized dealer is the best source of replacement parts and service. To obtain prompt, efficient service, always remember to give the following information...

- Correct Part Description and/or part number.
- Model number/Serial number of your sprayer.

Part descriptions and part numbers can be obtained from the illustrated parts list section(s) of this manual.

Whenever you need parts or repair service, contact your distributor/dealer first. For warranty work, always take your original sales slip, or other evidence of purchase date, to your distributor/dealer.

Technical Specifications

- 25 Gal. Corrosion-Resistant Polyethylene Tank
- 12 Volt Diaphragm Pump, 3.8 g.p.m. - 45 p.s.i.
- Deluxe Pistol-Grip Handgun w/15 Ft. Handgun Hose
- 26 Ft. max. vertical throw, 43 Ft. max. horizontal throw
- Pressure Gauge
- Adjustable Pressure
- 30 Foot Spray Coverage w/Boom
- Corrosion-Resistant Nozzles

Caution: Always check the vehicle load rating before using this sprayer. The loaded weight of the sprayer and boom assembly is about 290 lbs. when the tank is full. Care must be taken not to tip the vehicle over backwards, especially when starting or accelerating.

Assembly

1. Install the tank mounting plates to the tank as shown in the exploded view drawing.
2. Place the tank with the brackets attached to your ATV carrier rack. Attach the mounting brackets to the cross members of the rack, using the hardware supplied. (See exploded view drawing)
3. Join the boom mounting brackets to the tank mounting brackets with the hardware shown.
4. Attach the boom to the boom mounting brackets with the (2) u-bolts and (4) whiz locknuts. Make sure the u-bolts are positioned within the grooves of the grommets on the boom tube.

NOTE: The purpose of these grommets is to prevent metal-to-metal contact between the u-bolts, boom tube, and boom mounting brackets.

The grommets will 'compress' as you tighten the whiz locknuts onto the u-bolts. Tighten just so that the boom tube will NOT rotate within the grommets. Alternate the tightening of the locknuts to provide even pressure on the grommet.

**** DO NOT OVER-TIGHTEN the whiz locknuts, as this may cause the boom tube to flatten slightly!**

5. Thread the pressure gauge into the reducing bushing at the far end of the manifold assembly. Use a good grade of thread sealant here, to insure no leaks.
6. Connect the wiring harness to the rear of the pump. Clip the alligator clip ends to a fully charged 12 Volt battery. Red wire to the 'Hot' connection, and black wire to the 'Ground'.



www.fimcoindustries.com

1000 FIMCO Lane, P.O. Box 1700, North Sioux City, SD 57049
Toll Free Phone: 800-831-0027 : Toll Free Fax: 800-494-0440

Form No. 1328 [5004821 (2/09)] Printed in the U.S.A.

*** IMPORTANT REMINDER ***

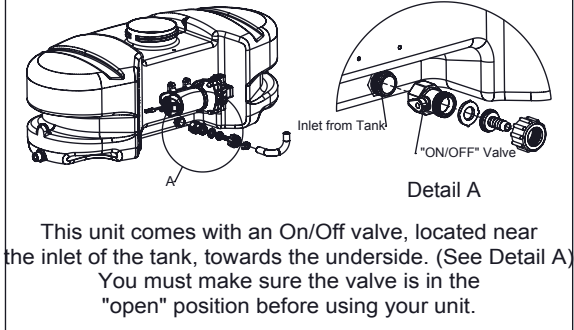

Speed Chart			
Speed in M.P.H. (Miles per Hour)	Time Required in seconds to travel a distance of:		
	100 Ft.	200 Ft.	300 Ft.
1.0	68 sec.	136 sec.	205 sec.
2.0	34	68	102
3.0	23	45	68
4.0	17	34	51
5.0	14	27	41
6.0	11	23	34
7.0	9.7	19	29
8.0	8.5	17	26
9.0	7.6	15	23
10.0	6.8	14	20

Operation

Your sprayer is equipped with (2) ON/OFF switches. One is on the wire assembly that you hook up to your battery, the other is on the pump itself, on the opposite end of the pressure switch. The "-" is the "ON" position and the "o" is the "OFF" position for the switches. Make sure both switches are depressed in the "-" position for operation.

In addition to the ON/OFF switch, the pump is equipped with an electronic pressure switch that is factory pre-set for it to shut off at 45 p.s.i.. This switch assembly is the 'square box' on the head portion of the pump.

Always fill the tank with a desired amount of water first, and then add the chemical slowly, mixing as you pour the chemical into the tank. You may use the handgun to spray into the solution in order to mix the chemical and water.

Initially begin spraying by opening the handgun. This will enable the air in the line to be purged through the handgun tip, while building pressure.

The pumping system draws solution from the tank, through the strainer/filter, and to the pump. The pump forces the solution under pressure to the handgun and/or boom nozzles.

- Open the handgun by squeezing the handle lever.
- Rotating the adjustable nozzle tip on the handgun will change the tip pattern from a straight stream to a cone pattern (finer mist).
- The pump's electronic pressure switch shuts the motor off when all lines are closed. The system will remain pressurized, and the pump motor will restart automatically when either the handgun, or boom line is opened. If the bypass line valve is in the open position, the pump will not shut off automatically.
- The (3) nozzles are fixed at 17 1/2" spacing.
- All (3) nozzles spraying at the same time will allow a maximum coverage of 30 feet.
- The center nozzle will spray an 80" swath.
- Each of the (3) nozzles has a shutoff valve, so you can shut off each nozzle individually. This may help in achieving the actual coverage needed for your application.

When it becomes necessary to clean the screen, you will need to shut off the ON/OFF valve down by the tank, on the inlet side of the pump. Next, unscrew the knurled nut on the outside of that valve. Remove the screen/washer which is located in the knurled nut at that location. Rinse and tap out the dirty screen and put back in it's original position when clean. Do this on a regular basis to maintain a clean screen.

Testing the Sprayer

NOTE:

It is VERY important for you to test your sprayer with plain water before actual spraying is attempted. This will enable you to check the sprayer for leaks, without the possibility of losing any expensive chemicals.

Add water to the tank & drive to the starting place for spraying. When you are ready to spray, turn the boom valve to the "on" position. This will start solution spraying from the tips of the boom. The pressure will decrease slightly when the boom is spraying. Adjust the pressure by turning the "ON/OFF" valve lever on the bypass line valve.

Read the operating instructions and initially begin spraying by closing the 'bypass' valve (this is the center ON/OFF valve located at the center port of your manifold assembly) and opening the boom line valve (this is the 'other' valve on the manifold). This will enable the air in the line to be eliminated (purged) through all the tips, while building pressure. When everything tests all right (no leaks, & good pressure), add the desired chemicals to the mixture and water combination and start your spraying operation. Adjust the pressure and spray as you did in the testing procedure.

Conditions of weather and terrain must be considered when setting the sprayer. Do not spray on windy days. Protective clothing must be worn in some cases.

Be sure to read the chemical label(s) correctly!

Calibration

Chemical labels may show application rates in gallons per acre, gallons per 1000 square feet, or gallons per 100 square feet. You will note that the tip chart shows all 3 of these rating systems.

Once you know how much you are going to spray, then determine (from the tip chart) the spraying pressure (PSI), and the spraying speed (MPH).

Determining the proper speed of the pulling vehicle can be done by marking off 100, 200, & 300 feet. The speed chart indicates the number of seconds it takes to travel the distances. Set the throttle and with a running start, travel the distances. Adjust the throttle until you travel the distances in the number of seconds indicated by the speed chart. Once you have reached the throttle setting needed, mark the throttle location so you can stop and go again, returning to the same speed.

Add water and proper amount of chemical to the tank and drive to the starting place for spraying.

Adjusting Pressure

- When the bypass valve is closed, pressure is at the highest point.
- Opening the valve will decrease pressure.

STOP WARNING STOP

DO NOT USE PUMP IN AN EXPLOSIVE ENVIRONMENT. DO NOT USE TO PUMP FLAMMABLE FLUIDS, GASOLINE, KEROSENE, FUEL, OIL, ETC.

CAUTION

PRESSURE SWITCH OPERATION

Pressure switch is pre-set at the factory. Improper adjustment of the pressure switch, may cause severe overload or premature failure. If the pump is subjected to rapid cycling during normal operation, or infrequent periods, damage may occur.

Using the Boom Nozzles

Four things must be considered before spraying with the boom:

1. How much chemical must be mixed in the tank.
2. Rate of spray (gallons per acre to be sprayed)
3. What pressure (p.s.i.) will be used.
4. Speed traveled (mph) while spraying.

- Refer to the chemical label to determine your chemical mixture.
- See the tip chart to determine the pressure to be used. The chart will also show the speed used when spraying.
- Start the pump and open the valve(s) to the boom nozzles.
- Check the spray pattern. Usually you can see the coverage better on a solid concrete surface, such as a driveway.
- The boomless nozzles should be approx. 33" above the objects being sprayed.

Rate Chart for Boomless Nozzles (Set of 3)

Gallons per Acre Based on Water - 17 1/2" Spacing								
Note: The same figures are used for 1, 2, or 3 nozzles.								
Pressure (p.s.i.)	Capacity (g.p.m.) (3 nozzles)	1 MPH	2 MPH	3 MPH	4 MPH	5 MPH	6 MPH	8 MPH
20	1.68	28.0	14.0	9.4	7.0	5.6	4.7	3.5
30	2.05	34.4	17.2	11.4	8.6	6.9	5.7	4.3
40	2.40	39.6	19.8	13.2	9.9	7.9	6.6	5.0
Gallons per 1000 Sq. Ft. based on Water - 17 1/2" Spacing								
Pressure (p.s.i.)	Capacity (g.p.m.) (3 nozzles)	1 MPH	2 MPH	3 MPH	4 MPH	5 MPH	6 MPH	8 MPH
20	1.68	0.64	0.32	0.21	0.16	0.13	0.11	0.08
30	2.05	0.78	0.39	0.26	0.20	0.16	0.13	0.10
40	2.40	0.90	0.45	0.30	0.23	0.18	0.15	0.12
Gallons per 100 Sq. Ft. based on Water - 17 1/2" Spacing								
Pressure (p.s.i.)	Capacity (g.p.m.) (3 nozzles)	1 MPH	2 MPH	3 MPH	4 MPH	5 MPH	6 MPH	8 MPH
20	1.68	0.064	0.032	0.021	0.016	0.013	0.011	0.008
30	2.05	0.078	0.039	0.026	0.020	0.016	0.013	0.010
40	2.40	0.090	0.045	0.030	0.023	0.018	0.015	0.012

MPH = Miles per Hour / FPM = Feet per Minute
p.s.i. = Pounds per Square Inch / GPM = Gallons per Minute

The rate of spray as shown in the chart will remain the same with 1, 2, or 3 nozzles.
The only difference will be the width of the spray swath.

End Nozzle Information (#5275122)

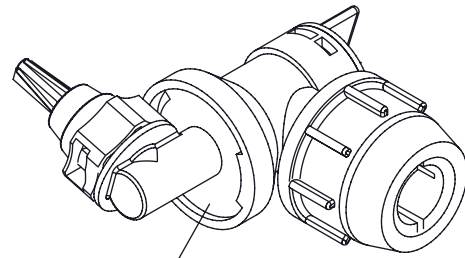

This nozzle mounting stem has a ratcheting motion.

** Each "click" of the ratcheting motion is approx. 15° **

For proper/optimal spray coverage, the nozzle must be at a 15° angle

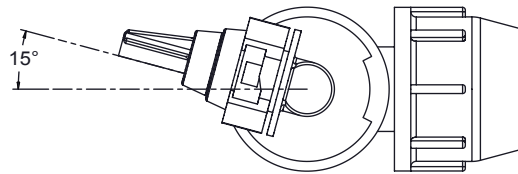

The 15° angle shown will prevent the outer nozzles from overlapping with the center nozzle.

After Spraying

After use, fill the sprayer tank part way with water. Start the sprayer, and allow the clear water to be pumped through the plumbing system and out through the spray nozzles. Refill the tank about half full with plain water and use a chemical neutralizer, such as 'Nutra-Sol', or equivalent, and repeat cleaning instructions above. A mix of water and some detergent, such as 'Dawn' dish soap would be a sufficient alternative. Flush the entire sprayer with the neutralizing/cleaning agent, then flush out one more time with plain water. Follow the chemical manufacturer's disposal instructions of all wash or rinsing water. For the boom, (if applicable) remove the tips and screens from the nozzle assemblies. Wash these items out thoroughly. Blow the orifice clean and dry. If the orifice remains clogged, clean it with a fine bristle (NOT WIRE) brush, or with a toothpick. Do not damage the orifice. Water rinse and dry the tips before storing.

WARNING: Some chemicals will damage the pump valves if allowed to soak untreated for a length of time! ALWAYS flush the pump as instructed after each use.

Winter Storage

Drain all water out of your sprayer, paying special attention to the pump, handgun, and valve(s). These items are especially prone to damage from chemicals and freezing weather.

The sprayer should be winterized before storage by pumping a solution of RV antifreeze through the entire plumbing system. This antifreeze solution should remain in the plumbing system during the winter months. When spring time comes and you are preparing your sprayer for the spray season, rinse the entire plumbing system out, clearing the lines of the antifreeze solution. Proper care and maintenance will prolong the life of your sprayer.

End Nozzle Assembly Procedure for Boomless "Wet" Boom

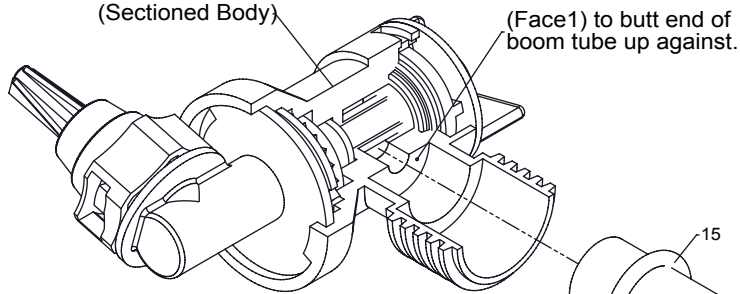
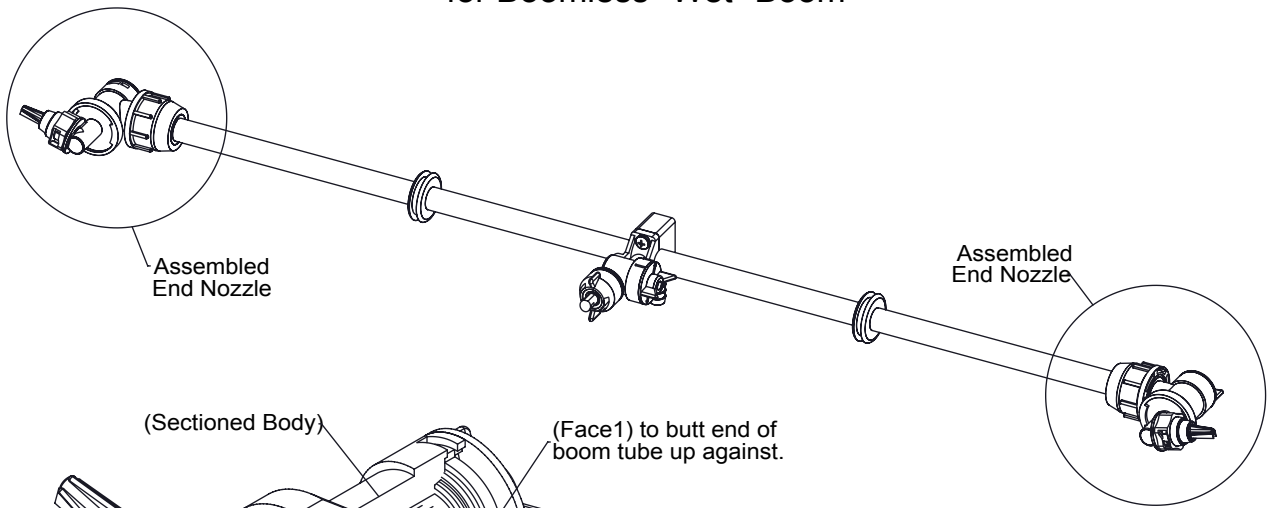

Your boom will come with the end nozzle assemblies (2) NOT affixed to your boom tube. Follow the instructions below to attach these properly to the boom tube, as shown.

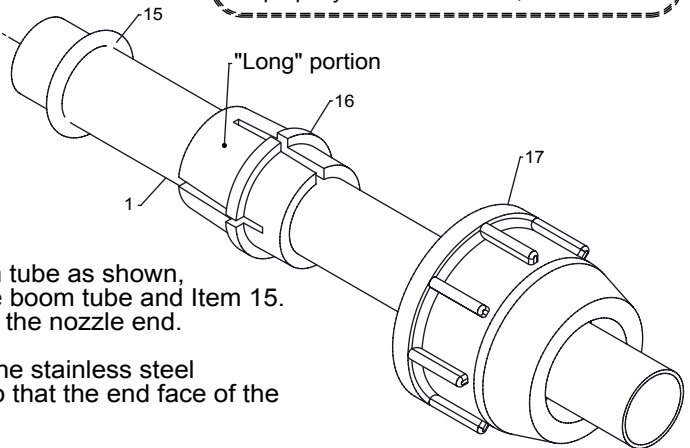

1. Start by sliding Item 17, 16, & 15 onto your boom tube as shown, leaving about 1/2" to 3/4" between the end of the boom tube and Item 15. Make sure the "Long" portion of Item 16 is facing the nozzle end.
2. Slide the (complete) end nozzle assembly onto the stainless steel boom tube, with a somewhat "twisting" motion so that the end face of the boom tube "butts" up against "Face1" as noted.
3. Now push the "compression olive" (Item 16) against o-ring (Item 15) and slide (both) into the nozzle body opening firmly.
4. Firmly tighten flynut (Item 17) onto threads of nozzle body.
5. Repeat for other side.

"On/Off" Valve Positions

Valve "Open"

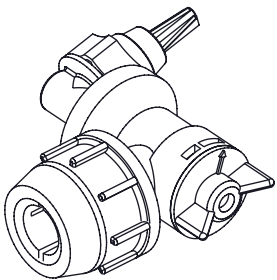

Valve "Closed"

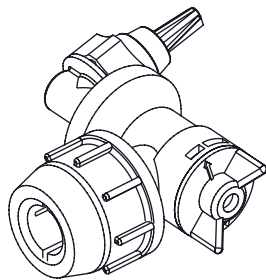

Service Position

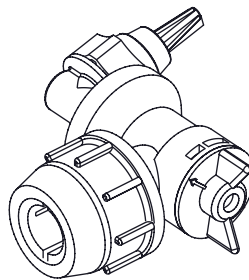

Eliminate line pressure, then pull out to check diaphragm condition.

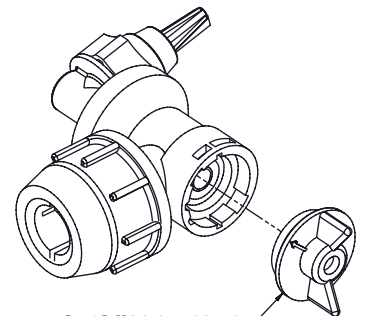

Note: The check valve & diaphragm can fall out during transport, if the knob is not turned to the "ON" or "OFF" position.

Troubleshooting a 3.8 g.p.m. Pump:

Pump will NOT run:

- Check inline fuse on the wires on the pump. If blown, replace with new fuse. (15 Amp mini-blade fuse #5157206)
- Make sure BOTH on/off switches are in the 'on' position (-).
- Make sure you 12 volt source (battery) is fully charged.
- Insure a tight connection at the battery clips.

If none of the above will work, try pulling wire terminal "A" off of the spade terminal of the pressure switch, and cross it over and touch terminal "B". (You will need to remove the pressure switch cap before doing this) If your pump runs when you do this, you know you will need to replace your pressure switch.

Another thing you can try is to take apart the switch box on the lead wire assembly (#5274443) with the (2) phillips head screws, and 'hot-wire' it together. Take the (2) wires that are screwed to the rocker switch, off of the switch and twist them together. This will insure you are getting the full 12 volts to the pump. If your pump runs after doing this, you will know that your lead wire assembly needs to be replaced.

Pump runs, but does not prime:

- Check line strainer (screen) at the inlet location, at the tank. You will need to unscrew the knurled nut to access this screen. (see exploded view later in this manual) The ON/OFF valve should be closed while performing this, to insure you do not lose any solution. Periodically take the screen at this location out and clean it.
- Make sure the bypass line valve is closed, to allow the pressure to build up in your system.
- Unscrew the head portion of your pump and remove the check valve assembly from inside. You need to make sure the O-Ring comes out with this piece as well. (See the exploded view to help identify these components) These pieces can be cleaned which, in most cases, will help restore some, if not most, of your prime. Soak this check valve in a solution of hot, soapy water. "Dawn" brand dishsoap works well for this. A little bit of 'scrubbing' with perhaps an old toothbrush may be required to actually break up any build-up that may be on the check valve. Rinse off the pieces and replace them back into your pump. Reassemble the pump. Hook it back up and test.

#5275704 Pump
(12 Volt, 11 Amp, 3.8 gpm, 45 psi)

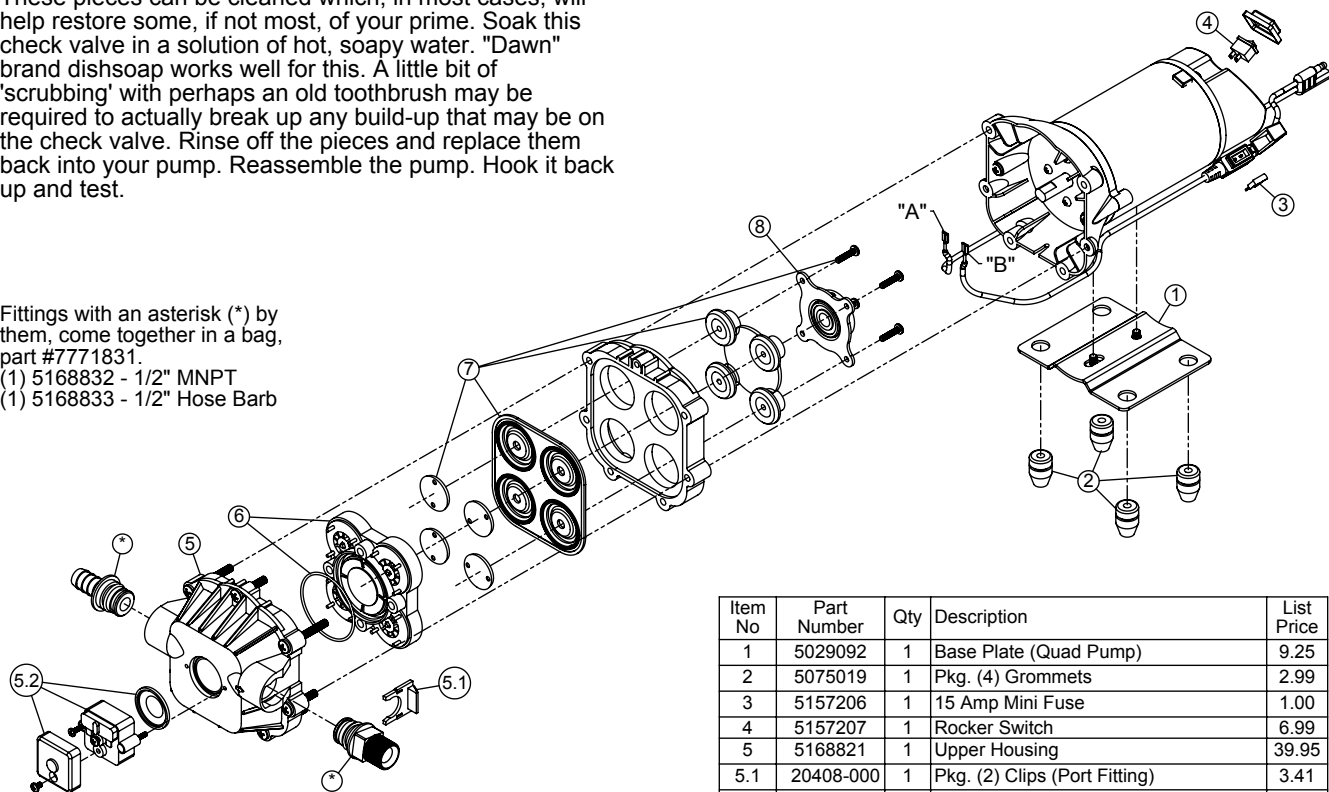

Fittings with an asterisk (*) by them, come together in a bag, part #7771831.

- (1) 5168832 - 1/2" MNPT
- (1) 5168833 - 1/2" Hose Barb

Item No	Part Number	Qty	Description	List Price
1	5029092	1	Base Plate (Quad Pump)	9.25
2	5075019	1	Pkg. (4) Grommets	2.99
3	5157206	1	15 Amp Mini Fuse	1.00
4	5157207	1	Rocker Switch	6.99
5	5168821	1	Upper Housing	39.95
5.1	20408-000	1	Pkg. (2) Clips (Port Fitting)	3.41
5.2	5157203	1	Pressure Switch Assembly	23.95
6	5168824	1	Check Valve Kit w/O-Ring & Ferrules	24.99
7	5168826	1	Diaphragm Kit w/Pistons & (4) Screws	19.96
8	5168828	1	Cam/Bearing Kit, w/Set Screw	12.95

Exploded View/Parts List:
LG-3025 (5301267)

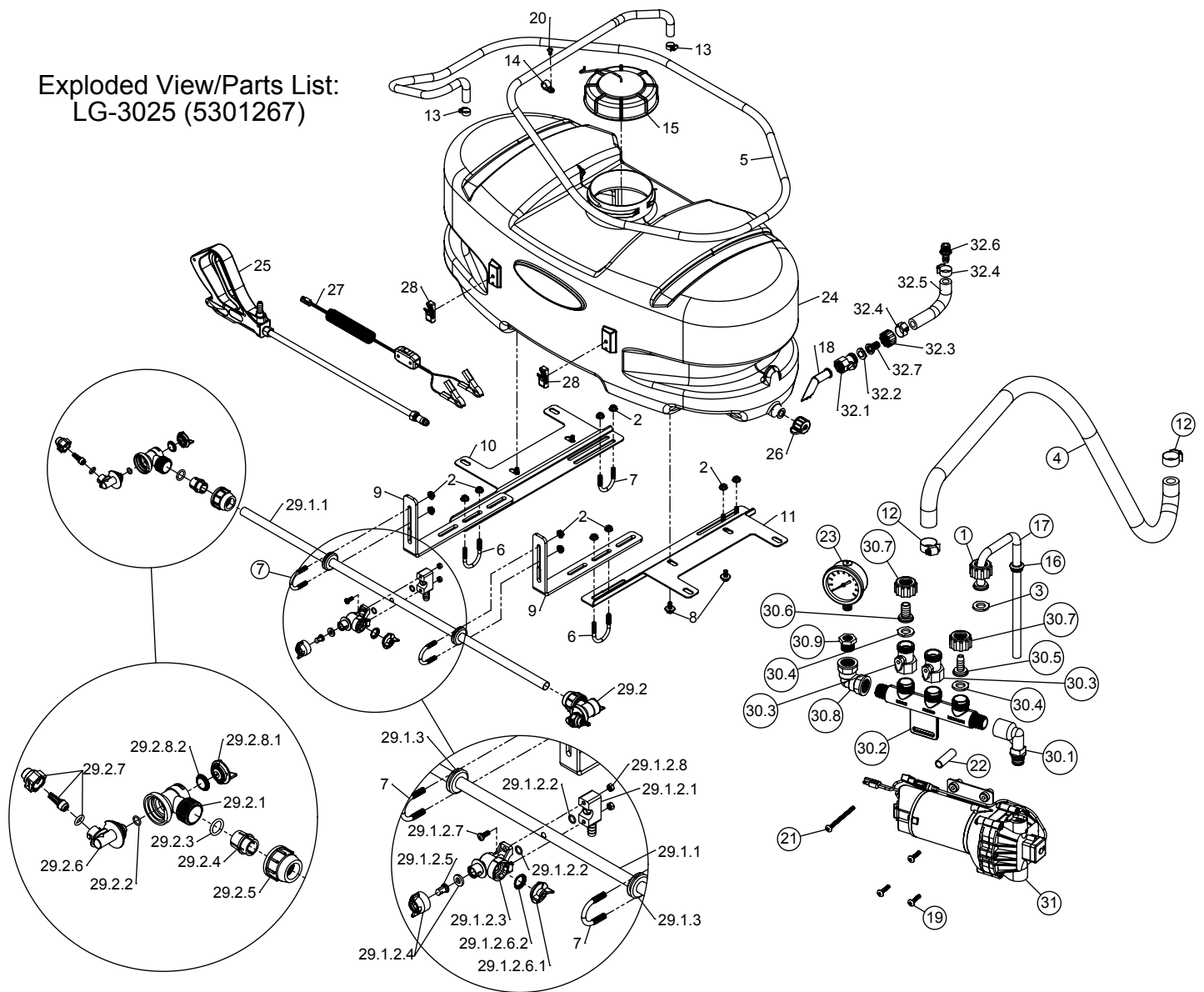

Item No	Part Number	Qty	Description	List Price
1	5006209	1	Poly Knurled Swivel Nut, 3/4" FGHT	.57
2	5006307	12	5/16"-18 Hex Whiz (Flange) Locknut	.25
3	5016066	1	Garden Hose Washer	.20
4	5020122	1	Hose, 1/2"-1 Brd. x 48"	5.88
5	5020215	1	Hose, 3/8"-1 Brd. x 15 Ft.	8.50
6	5034065	2	Round U-Bolt, 5/16"-18 x 1 1/2" x 2 3/16"	1.15
7	5034220	4	Round U-Bolt, 5/16"-18 x 1 5/16" x 1 3/4"	.50
8	5034531	4	5/16"-18 x 5/8" Flange Lock Screw	.44
9	5038665	2	Boom Mounting Bracket	6.18
10	5038667	1	Tank Mounting Plate (L.H.) (ATV)	11.06
11	5038725	1	Tank Mounting Plate (R.H.) (ATV)	11.06
12	5051022	2	Hose Clamp, 1/2"	.62
13	5051114	2	Hose Clamp, 3/8"	.63
14	5051122	1	5/8" Black Nylon Loom Cable Clamp	.25
15	5058188	1	Tank Lid w/Lanyard	10.50
16	5075018	1	Grommet	1.00
17	5100359	1	Poly Bypass "J" Hose (3.8 Pumps & 2.1 [25] Gallon)	1.95
18	5100452	1	Siphon Tube	1.20
19	5117168	3	#10-24 x 1" Phillips Truss Head Machine Screw	.25
20	5117234	1	#10-24 x 1/2" Phillips Truss Head Machine Screw	.25
21	5117314	1	#10-24 x 3" Truss Head Machine Screw	.25
22	5127192	1	Manifold Spacer (3.8gpm)	.40
23	5167031	1	Gauge, Liquid-Filled, 0-100# p.s.i.	21.75
24	5169243	1	25 Gallon (New Style) Tank	60.00
25	5273959	1	Handgun w/X-26 Tip	24.95
26	5274373	1	Drain Plug Cap, Tether, and Washer Assembly	2.95
27	5274443	1	Lead Wire Assembly (w/Switch), 96"	9.99
28	5274880	1	Pkg. (2) Handgun Clips & (2) Screws	2.85
29	5275260	1	"Wet Boom" Assembly	169.00
29.1	5275712	1	Wet Boom Sub-Assembly	55.28
29.1.1	5100316	1	Boom Tube	23.55
29.1.2	5275123	1	Center Nozzle Assembly (Wet Boom)	15.96
29.1.2.1	5051137	1	Hose Barb Saddle	3.25
29.1.2.2	5072509	2	O-Ring	.49

Item No	Part Number	Qty	Description	List Price
29.1.2.3	5002500	1	Body	5.99
29.1.2.4	5274862	1	Center Boomless Nozzle Cap w/Gasket	1.35
29.1.2.5	5018329	1	Red Spray Tip	6.99
29.1.2.6.1	5088024	1	Yellow ON/OFF Valve Knob (w/Diaphragm)	3.18
29.1.2.6.2	5063255	1	Diaphragm	1.05
29.1.2.7	5117310	2	SS Screw, 6mm x 16mm (5/8")	.95
29.1.2.8	5006347	2	SS Nut, 6mm	1.25
29.1.3	5075016	2	Rubber Grommet	1.99
29.2	5275122	2	End Nozzle Assembly (Wet Boom)	56.86
29.2.1	5002499	1	Nozzle Holder Body	6.00
29.2.2	5072518	1	Stem O-Ring	.50
29.2.3	5072517	1	Compression O-Ring	.50
29.2.4	5010427	1	Compression Olive	1.50
29.2.5	5006348	1	Flynut	2.50
29.2.6	5132073	1	Nozzle Holder Stem	4.99
29.2.7	5274861	1	XT Spray Nozzle, Cap, & O-Ring	39.95
29.2.8.1	5088024	1	Yellow ON/OFF Valve Knob (w/Diaphragm)	3.18
29.2.8.2	5063255	1	Diaphragm	1.05
30	5275516	1	Manifold Assembly	18.00
30.1	5010430	1	Port Kit Elbow, 1/2" FNPT	2.79
30.2	5143405	1	Manifold w/Mounting Tab	6.99
30.3	5143188	2	Nylon Shut-Off Valve	3.04
30.4	5016066	2	Garden Hose Washer	.20
30.5	5149034	1	Poly Swivel, 3/8" Hose Barb	.50
30.6	5149035	1	Poly Swivel, 1/2" Hose Barb	.50
30.7	5006209	2	Poly Knurled Swivel Nut, 3/4" FGHT	.57
30.8	5010236	1	Poly Elbow, 1/2" FNPT x 1/2" FNPT	2.07
30.9	5041073	1	Poly Reducing Bushing, 1/2" MNPT x 1/4" FNPT	1.24
31	5275704	1	Gold Series 3.8 g.p.m. Pump	159.00
32	5275877	1	Intake Sub-Assembly	7.49
32.1	5143188	1	Nylon Shut-Off Valve	3.04
32.2	5116242	1	Strainer, 1" Filter Washer	.31
32.3	5006209	1	Poly Knurled Swivel Nut, 3/4" FGHT	.57
32.4	5051022	2	Hose Clamp, 1/2"	.62
32.5	5020497	1	1/2" Polyspring Hose x 6"	1.69
32.6	5168833	1	Port Kit Fitting, 1/2" Hose Barb	2.24
32.7	5149035	1	Poly Swivel, 1/2" Hose Barb	.50