



Model 880 Two Wheel Hose Cart Owner's Manual



**VISIT OUR WEBSITE: WWW.LIBERTYGARDENPRODUCTS.COM
OR CALL US TOLL FREE AT 1-866-820-5805, MONDAY - FRIDAY 9 A.M. - 5 P.M.**

LIBERTY GARDEN PRODUCTS, INC.
1161 SOUTH PARK DRIVE, KERNERSVILLE NC 27284

IMPORTANT: READ THE OWNER'S MANUAL BEFORE ASSEMBLING

TOOLS REQUIRED: TWO ADJUSTABLE WRENCHES & HAND PUMP

Estimated Assembly time: 30 minutes

PARTS LIST

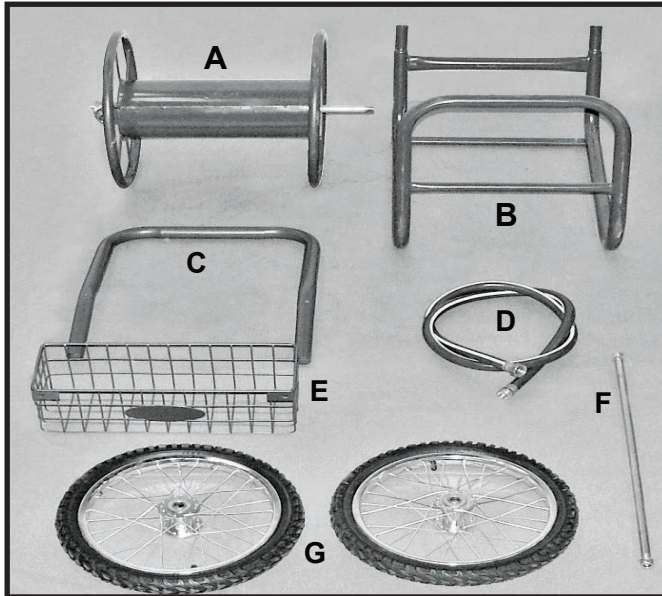

- A.** SPOOL (1)
- B.** FRAME (1 UNIT)
- C.** U-HANDLE (1)
- D.** LEADER HOSE (1)
- E.** BASKET (1)
- F.** AXLE W/WASHERS/NUTS (1)
- G.** TIRES (2)

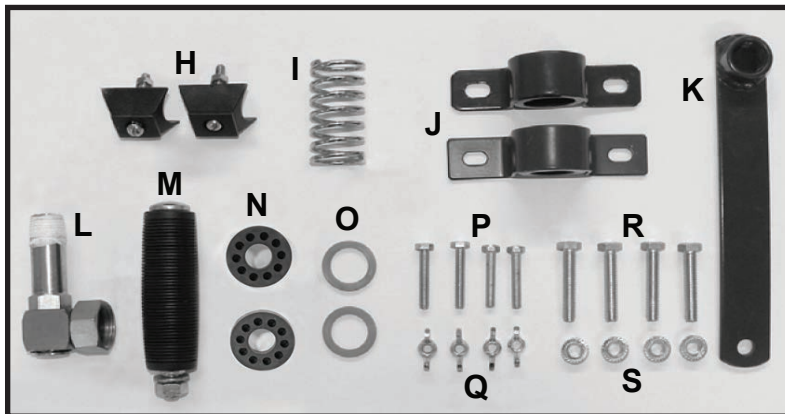

- H.** RUBBER FEET W/NUTS (2)
- I.** SPRING (1)
- J.** U-BUSHING (2)
- K.** CRANK HANDLE (1)
- L.** BRASS SWIVEL (1)
- M.** HANDLE W/BOLT AND NUT (1)
- N.** TIRE SPACERS (2)
- O.** SPACER WASHERS (2)
- P.** HANDLE BOLTS (4)
- Q.** HANDLE WING NUTS (4)
- R.** U-BUSHING BOLTS (4)
- S.** U-BUSHING NUTS (4)

IMPORTANT: LAY OUT ALL PARTS AND FASTENERS. MAKE SURE ALL PARTS ARE ACCOUNTED FOR.

IF ANY PART IS MISSING PLEASE CONTACT LIBERTY GARDEN PRODUCTS AT **1-866-820-5805**

MONDAY - FRIDAY 9:00 A.M. - 5:00 P.M. EST. DO NOT CONTACT THE RETAILER.

YOU CAN ALSO VISIT OUR WEBSITE, WWW.LIBERTYGARDENPRODUCTS.COM, FOR MORE INSTRUCTIONS PICTURES AND HELPFUL HINTS.

CART ASSEMBLY

1. Attach rubber feet (**H**) to the bottom frame (**B**). Insert bolts into bottom of frame. Attach nuts and tighten. See Figure 1.

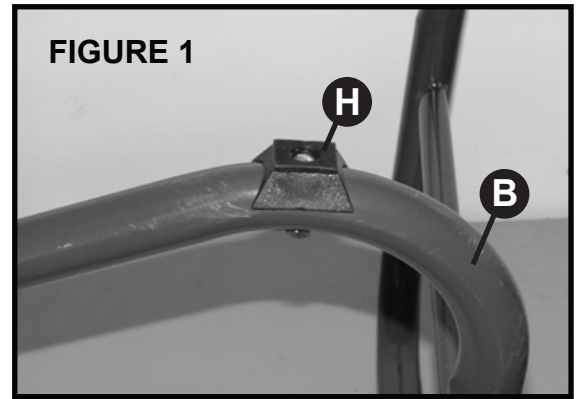

2. Turn frame (**B**) over and attach U-bushing (metal side facing out) (**J**) to frame using two U-bushing bolts (**R**) and nuts. (**S**) Hand tighten only.

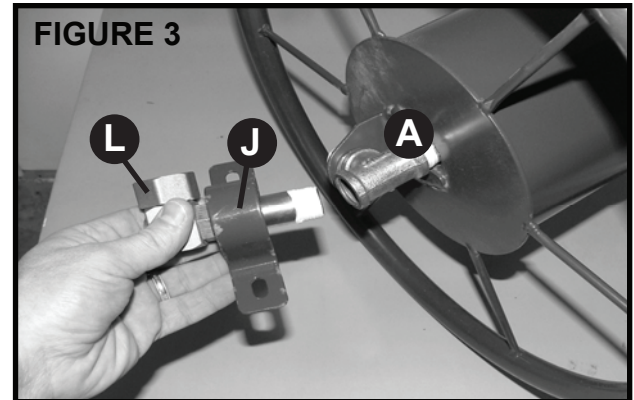
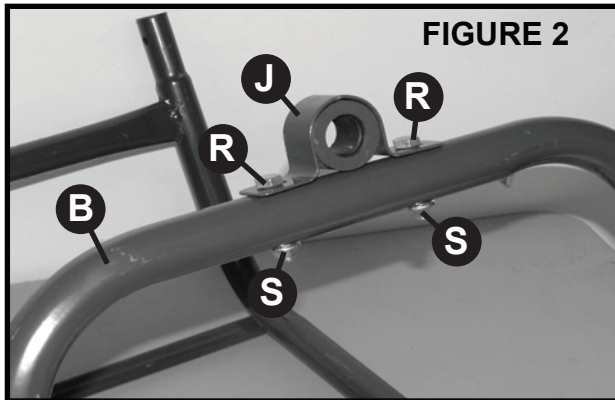

3. Spool Assembly: Insert brass swivel (**L**) thru U-bushing (**J**) and screw into galvanized tee on the spool (**A**). Tighten using a wrench. See Figure 3. **DO NOT** overtighten, this could damage the threads. Be sure to use Teflon / Plumbers's tape on threads.

4. Turn spool (**A**) around and slide plastic spacer washer (**O**), spring (**I**) and another plastic spacer washer (**O**) over the pipe. See Figure 4.

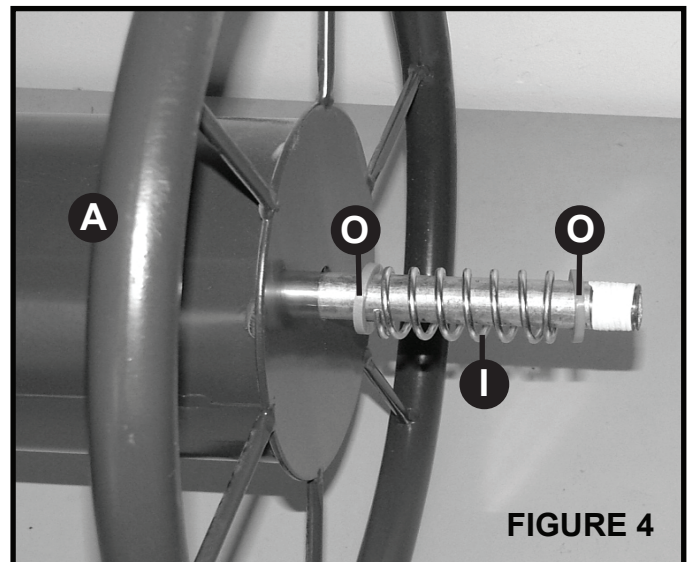

CART ASSEMBLY

5. Attaching spool to the frame: Insert “Pipe” end of spool into U-bushing (J) that is attached to frame (B). See Figure 5.

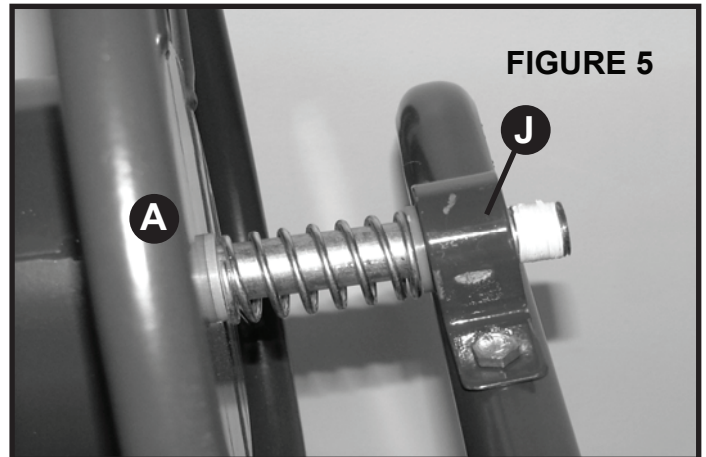

6. On the other end of spool (A), align the other U-bushing (J) with the holes in the frame and insert U-bushing bolts (R) and attach nuts (S). You may need to put pressure on the spool by compressing the spring to align holes. Tighten all four U-bushing nuts (S) using a wrench. See Figure 6.

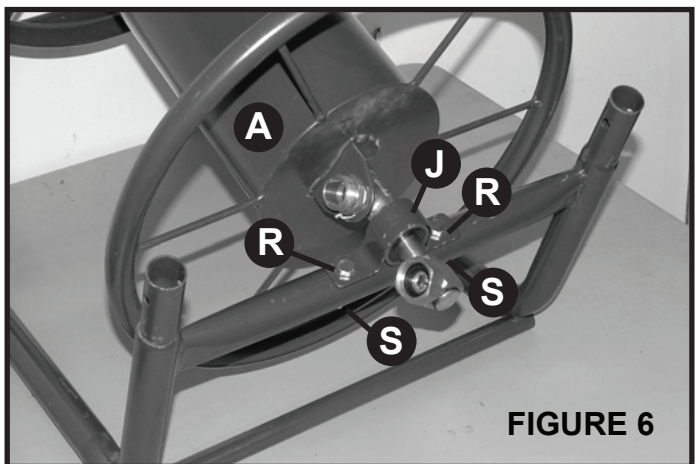

7. Attach handle (M) to crank handle (K) using handle bolt and nut. Tighten securely. Attach crank handle to pipe on end of spool (A). See Figure 7.

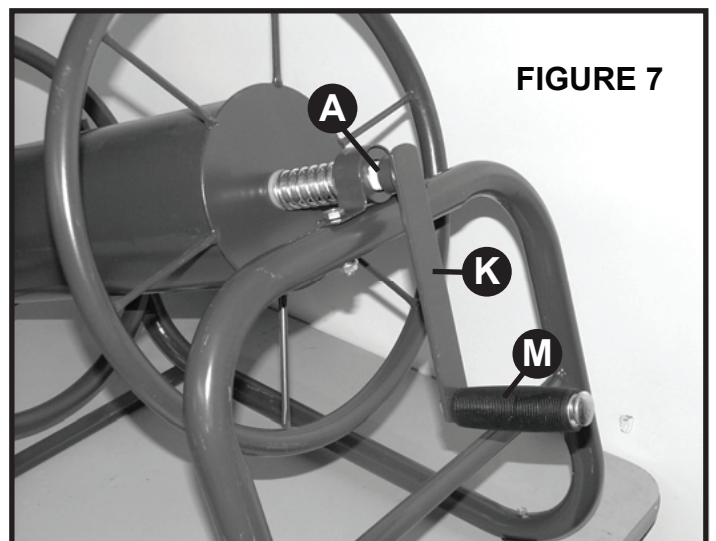

CART ASSEMBLY

8. Attach wheels (G) by removing nuts on axle. Slide axle (F) thru the frame (B). Before adding wheels (G) slide the plastic spacers (N) thru both ends of the axle (F) Slide on wheels (G) and tighten nuts on each end.

See Figure 8.

NOTE: DO NOT use a compressor while inflating the tires; hand pump only. 30 PSI maximum.

9. Attach basket (E) using handle bolts (P) and fasten with wing nuts (Q) to the U-handle (C). Slide the U-handle (C) over the frame extensions and align the holes. Insert handle bolts (P) through the holes in the U-handle and fasten with wing nuts (Q) Hand tighten. See Figure 9

10. Attach the leader hose (D) to the end of the brass swivel (L). **DO NOT OVER TIGHTEN.** See Figure 10

Note: If you have trouble with the swivel turning and kinking the leader hose, try spraying a silicone spray inside to lubricate the O-rings. The O-rings located inside the swivel may be dry. You can reach the O-rings by taking off the retaining clip or spraying inside the opening of the swivel.

11. Attaching your garden hose: Attach your hose to the galvanized tee. Loop the hose over the spool end to avoid kinking. See Figure 11

Your Model 880 hose cart is now ready to use. Attach the end of the leader hose to a water source.

- **DO NOT** leave water running through the hose reel unsupervised.
- **DO NOT** expose the reel to freezing temperatures with water remaining in the unit.
- Turn the water off after each use.

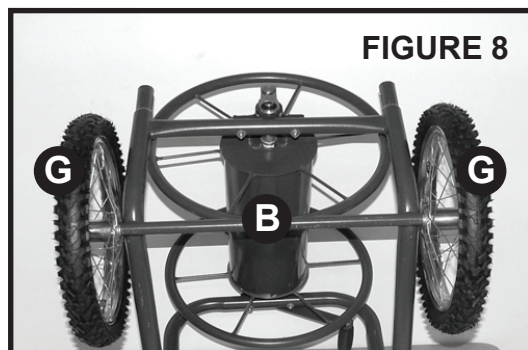

FIGURE 8

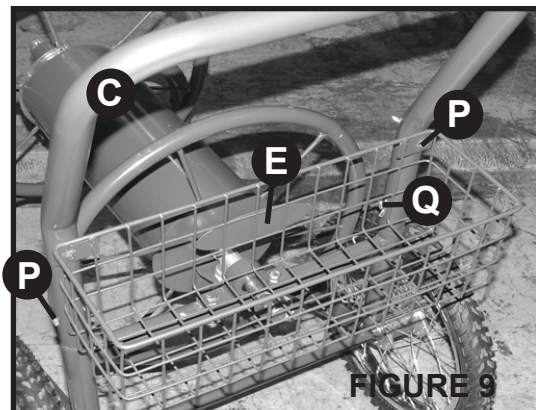

FIGURE 9

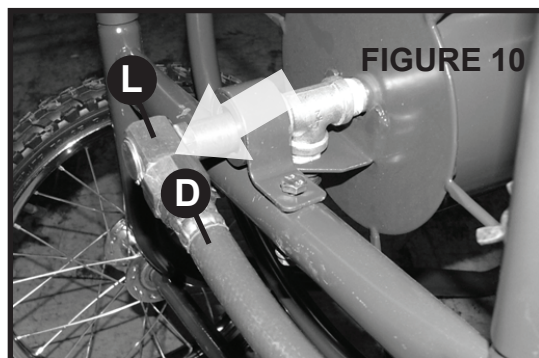

FIGURE 10

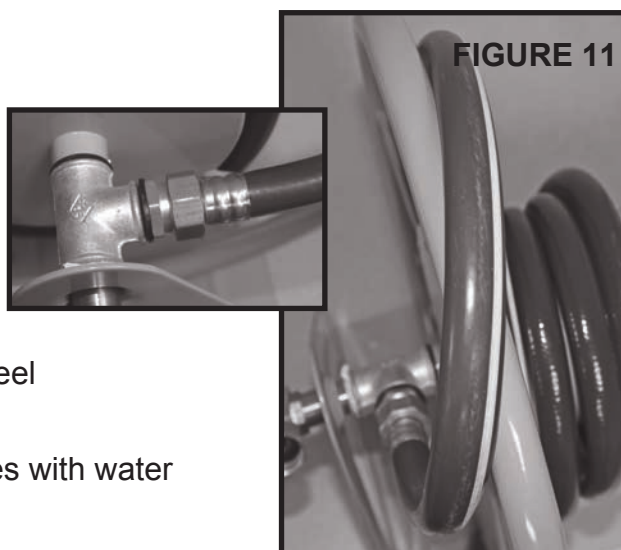

FIGURE 11

Model 880 not shown in Figure 11

CURING A LEAKING SWIVEL

Problem:

Your new Liberty™ model 880 hose cart is leaking at the swivel.

Solution:

It is normal for the swivel to leak slightly until the O-rings are wet and have seated. If the leaking continues, you don't need to take the cart back to the store. This is a simple problem and is easily fixed by a simple procedure.

1. If the leader hose is attached to the swivel, unscrew the hose and look inside the swivel.
2. Using either a hex key or a large screw driver, insert the tool into the hex opening and gently tighten the threaded insert. **DO NOT OVER TIGHTEN!**
3. This should stop the leaking.
4. If the unit still leaks, please check that the hose washer is inside the nut. You may contact Liberty for a new hose washer or obtain one at any hardware store.
5. If your swivel is old, the O-rings may be worn, please contact us for a new set of O-rings.
6. If these steps do not solve your leaking problem, then contact Liberty Garden.

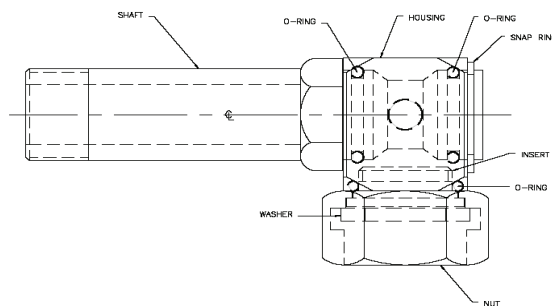
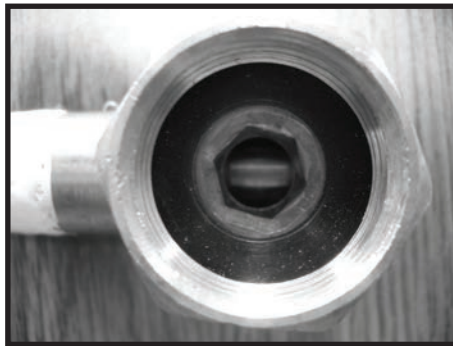

**CALL US AT 1-866-820-5805 IF YOU HAVE ANY QUESTIONS
REGARDING TROUBLESHOOTING AND WARRANTY**

CARE INSTRUCTIONS

Rust

Your hose reel will give you many seasons of reliable and functional hose storage. As with any steel product, there is always the chance for rust developing over time. Your hose reel finish is designed for industrial applications, but even the toughest of coatings can be compromised by scratches. Such minor surface damage can occur in shipping despite our best efforts. We have found that most scratches occur during assembly and/or installation. If the base metal is exposed to the elements long enough, rust will develop. We recommend that you periodically inspect your reel for any surface damage. Scratches can easily be repaired by using standard automotive touch-up body paint. Some of our most loyal customers recommend that at the end of each season, the unit be cleaned and painted with a clear acrylic paint. Two other sources of rust acceleration is exposing the reel to yard fertilizers or leaving your hose reel standing in grass. Be sure to rinse off your hose reel after it comes in contact with freshly fertilized grass. Also, try to park your hose reel on solid ground. Leaving it standing on top of vegetation promotes condensation on the undercarriage of the unit.

Leaks

Your hose reel is manufactured with the finest quality components available. All components are manufactured to rigorous quality standards not common in other consumer grade hose reels available today. When you install your hose reel, be sure the hose washers are in place and all fittings are secure. **DO NOT OVER TIGHTEN** as you might damage the components. If you live in more temperate climates, be sure to drain the unit of any residual water before storing. **DO NOT EXPOSE THE UNIT TO FREEZING TEMPERATURES** while water remains in the plumbing system.

Troubleshooting Guide

Problem: Swivel head is not rotating, causing the leader hose to kink up.

Solution: Remove leader hose and turn the square head of the swivel several times; apply lubricant.

Problem: Leaking Fixtures (galvanized tee; brass coupling; swivel)

Solution: Apply Teflon/Plumber's Tape or/and make sure fixtures are tightened.

TIPS

- **DO NOT** use a compressor while inflating the tires; hand pump only. 30 PSI maximum.
- To help delay rust, check for any scratches on your hose cart. Apply clear acrylic/weatherproof paint to avoid rusting.
- Drain water before storing.
- **DO NOT** drink water from the hose.
- **DO NOT** leave water running though the reel while not in-use or unsupervised.
- Turn off water after each use.

WARRANTY & CARE

Our guarantee is as functional and straight-forward as our products. Since we design and build our products to provide you with many years of satisfaction, all Liberty™ products are guaranteed against defects in materials and workmanship. In the unlikely event that a problem arises as a result of a defect in our materials or workmanship, we will promptly repair or replace the item at our expense. All we require is that you contact us first and we'll take it from there. It is important to note that our guarantee is not an unconditional guarantee for the life of the product. Liberty™ hose stands and reels are made from the finest materials available under our exacting manufacturing standards. But, like any other product, it is not indestructible. Therefore, our guarantee does not cover:

- Product damage that is a result of abuse, misuse, or mishandling. (Exposing the unit to freezing temperatures with water remaining in the reel plumbing system voids the unit warranty).
- Rust. Despite the industrial quality coating and our best efforts, steel will rust over time.
- Incidental damage or consequential damages or injury to persons or to other property not purchased from us due to the use of our product.
- **DO NOT** consume water from garden hose; not fit for human consumption.

If there is damage to the product that occurred as a result of shipping, you should file a damage claim with the carrier.

- **DO NOT** leave water running though the reel while not in-use or unsupervised.

As with any product, it should be expected that component parts - particularly moving parts, seals, O-rings, wheels, hose, and connectors will wear with use and over time, and eventually may need to be replaced or refurbished. This type of normal wear and tear is naturally not covered by our guarantee, but we will always be happy to provide you with prompt, high quality service and replacement parts at a nominal cost.

This warranty gives you specific legal rights, and you may also have other rights which vary from state to state. (Some states do not allow the exclusion or limitation of incidental or consequential damages, so the above limitation may not apply to you).

You will find that we apply the same standard of excellence to our customer service as we do to our products.

Warning! This product contains one or more chemicals known to the state of California to cause cancer and birth defects or other reproductive harm. Wash hands after handling.



LIBERTY GARDEN PRODUCTS, INC.
1161 SOUTH PARK DRIVE, KERNERSVILLE NC 27284

Updated 11/26/2013