

# **Dissolved Oxygen Pen Meter**

850045

Instruction Manual

SPER  
SCIENTIFIC

*Environmental Measurement Instruments*

## TABLE OF CONTENTS

Features .....	3
Front Panel Description .....	4
Calibration .....	5-6
Measurement Procedures .....	7-9
Probe Maintenance .....	10-11
Specifications .....	12-13
Battery Replacement .....	14

## **FEATURES**

- Heavy duty polarographic D.O. probe including temperature sensor
- Automatic Temperature Compensation
- Microprocessor assures high accuracy
- Dual display LCD
- Auto power off
- IP-67 water resistance.
- Maximum and Minimum
- Data hold

# FRONT PANEL DESCRIPTION

FIGURE 1

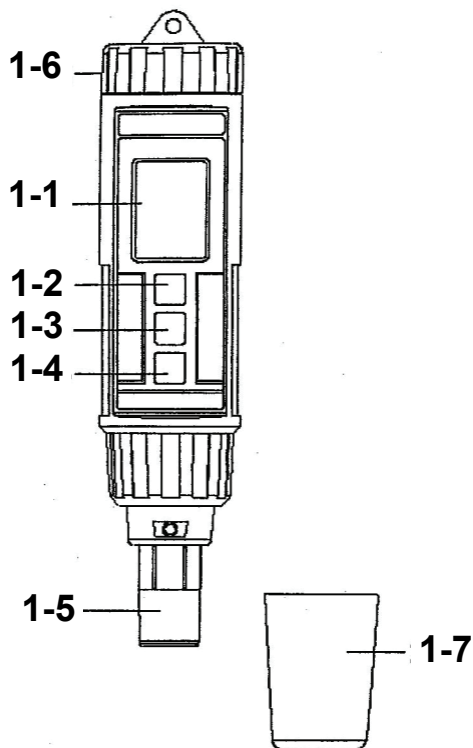

- 1-1 Display
- 1-2 Power button
- 1-3 HOLD button ( Unit button )
- 1-4 REC button ( °C, °F button )
- 1-5 Probe head with diaphragm set
- 1-6 Battery compartment/Cover
- 1-7 Protection cover for probe head

# CALIBRATION

## Calibration

1. Fill the D.O. meter probe head (completely) with Electrolyte prior to using the first time. Please refer to the Probe Maintenance section (page 10) for instructions.
2. Prior to taking measurements, the D.O. meter should be calibrated using the following steps.
3. Remove the red protective cover (Fig., 1-7) from the black probe head (Fig., 1-5). \*The small sponge inside the red cover keeps the diaphragm moist with water.
4. To turn the meter on, press the **Power** On/Off button (Fig., 1-2).
5. The LCD display (Fig., 1-1) will show %O<sup>2</sup> and Temperature - see example below.

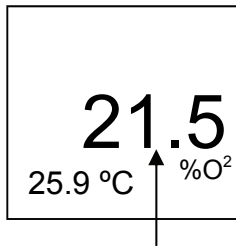

*Wait for approximately three (3) minutes until the upper display value stabilizes.*

## CALIBRATION

6. Press and release the **HOLD** button (Fig., 1-3) - the display will read HOLD.
7. Press and release the **REC** button (Fig., 1-4) - the display will show a flashing CAL indicator and the upper value will change to 30, then countdown to 0 (takes 30 seconds).

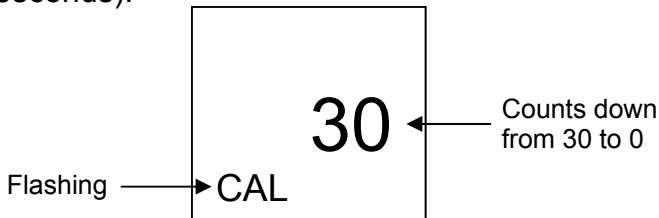

8. Once the countdown has been completed, the End indicator will be displayed momentarily, then display will return to the normal display as shown on page 3.

*Perform the calibration procedure in an open and well ventilated area to achieve the best possible results. Once the calibration is complete the meter should read approx. 20.9 as this is the typical amount of O<sup>2</sup> in the air.*

# MEASUREMENT PROCEDURES

## Dissolved Oxygen (DO) Measurement

1. Make certain the meter has been calibrated (page 5).
2. Press and hold the **Unit** button (Fig., 1-3) for at least 2 seconds, the display will change from %O<sup>2</sup> to mg/L.
3. The meter is now ready to measure.
4. To activate Automatic Temperature Compensation the probe head (Fig., 1-5) must be immersed to a depth of 10cm. It takes several minutes for the temperature of the probe and liquid to equalize.
5. For accurate D.O. measurement of any liquid, the probe should be moving. Make sure that the velocity of the movement is at least 0.2 - 0.3 m/s. This can be achieved by shaking the probe.

### **Note...**

To keep errors to a minimum during laboratory measurements, use of a magnetic agitator is recommended.

6. Rinse the probe with tap water after each measurement.
7. Re-install the probe head's protector cover (Fig., 1-7).

# MEASUREMENT PROCEDURES

## Temperature Measurement

1. When not in calibration mode, the meter continually displays the temperature at the bottom left hand corner of the LCD in either °C or °F.
2. Press and hold the **REC** button (Fig., 1-4) for at least 2 seconds to switch the temperature unit from °C to °F.

### Note...

The temperature unit cannot be changed when the meter is in record mode (when the REC indicator is displayed on the LCD).

## Data Hold

1. While measuring, press the **Hold** button (Fig., 1-3) to hold the displayed value. The LCD will show the HOLD symbol.
2. Press the **Hold** button once again to release the data hold function.



# MEASUREMENT PROCEDURES

## Data Record (Maximum & Minimum Reading)

1. The data record function records the maximum and minimum readings. Press the **REC** button (Fig., 1-4) to start the Data Record function - the display shows REC.
2. Press the **REC** button: the REC MAX symbol, along with the maximum value shows on the display.
3. Press the **REC** button again and the REC MIN symbol, along with the minimum value shows on the display.
4. To exit the record function, press and hold the **REC** button for a minimum of 2 seconds. The display will return to the current reading.

# PROBE MAINTENANCE

## Initial Use

1. Unpack the DO meter and fill the probe head with the Electrolyte (OXEL-03) fluid provided.
2. Follow the steps shown in Figure 2.

## Probe Head & Fluid Maintenance

1. Whenever the DO meter will not calibrate correctly or the DO reading is unstable, check to see if the Electrolyte fluid is dirty or has evaporated.
2. If the Electrolyte fluid needs to be replaced, refill the probe head (completely), following the steps shown in Figure 2 and recalibrate the DO meter (see page 3)
3. If the fluid has been replaced and the DO meter still does not calibrate correctly or give a stable reading, check the probe head diaphragm for damage.
4. The Teflon diaphragm is delicate and can be damaged if it comes in contact with solid objects or if the meter is dropped.

## PROBE MAINTENANCE

3. If the diaphragm is damaged replace it with one of the spare probe heads provided with the meter.
4. Refill the new probe head with Electrolyte fluid by following the steps shown below.

**Figure 2**

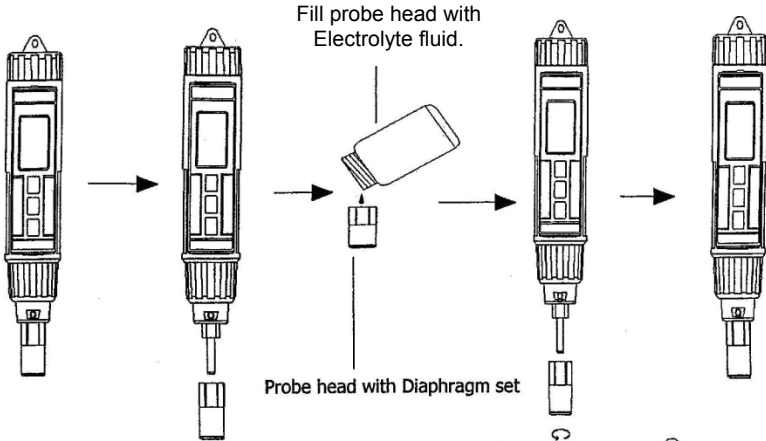

1. Unscrew the probe head (Fig., 2-3)
2. Pour out the current Electrolyte fluid from the probe head (unless this is the initial use).
3. Fill the probe head (to full capacity) with fresh Electrolyte (OXEL-03) fluid.
4. Screw the probe head back on to the probe body.

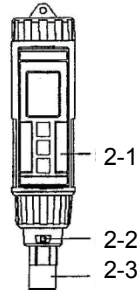

## SPECIFICATIONS

Display	LCD size: 29mm x 28mm
Measurement & Range	Dissolved Oxygen: 0 to 20.0 mg/L
	Temperature: 0 to 50 °C 32 to 122 °F
Resolution	Dissolved Oxygen: 0.1 mg/L
	Oxygen in Air: 0.1% O <sup>2</sup>
	Temperature: 0.1 °C
Accuracy	Dissolved Oxygen: ±0.4 mg/L
	Oxygen in Air: ±0.7% O <sup>2</sup>
	Temperature: ±0.8 °C/1.5 °F
Power Off	Auto shut off
Data Hold	Holds the current displayed reading
Operating Temperature	0 to 50 °C 32 to 122 °F
Sample Time	Approx. one (1) second
Operating Humidity	Less than 80% RH
Power Supply	4-AAA Alkaline Batteries
Weight	176g / .4LB -includes battery and probe

## SPECIFICATIONS

Water Resistance	IP-65: 0 to 50 °C - 32 to 122 °F IP-67: 0 to 30 °C - 32 to 86 °F
Dimension	180 x 40 x 40mm 8.1" x 1.9" x 1.6"
Accessories Included	Instruction manual, spare probe head/ diaphragm set (2), Electrolyte fluid (OXEL-03), soft carrying case and batteries

## BATTERY REPLACEMENT

1. Replace the batteries when the low battery icon  is displayed in the upper left corner of the LCD.  
Use 4 new AAA batteries.
2. To replace the batteries, open (turn counter-clockwise) the Battery Cover (Fig., 1-6).
3. Ensure the Battery Cover is secured after replacing the batteries.

**Sper Scientific** warrants this product against defects in materials and workmanship for a period of one (1) years from the date of purchase, and agrees to repair or replace any defective unit without charge. If your model has since been discontinued, an equivalent Sper Scientific product will be substituted if available. This warranty does not cover probes, batteries, or damage resulting from accident, misuse, or abuse of the product. In order to obtain warranty service, simply ship the unit postage prepaid to:

**SPER SCIENTIFIC LTD.**  
7720 East Redfield, Suite 7  
Scottsdale, AZ 85260  
Email: [info@sperscientific.com](mailto:info@sperscientific.com),  
Phone: (480) 948-4448

Be sure to include your name, address, phone number, and a detailed explanation of why you are returning the item. Mail your warranty card within 10 days or register on line at:  
[www.sperscientific.com](http://www.sperscientific.com).



