

TidbiT® v2 Temp (Part # UTBI-001)

Inside this package:

- TidbiT v2 Temp logger



Doc #10385-C, MAN-UTBI-001
Onset Computer Corporation

Thank you for purchasing an Onset data logger. With proper care, it will give you years of accurate and reliable measurements.

The TidbiT v2 Temp logger is Onset's smallest U-Series logger. Its durable, waterproof case is designed for extended deployments measuring temperature in streams, lakes, oceans, coastal habitats, and soils.

The logger's small size allows it to be easily mounted and/or hidden in the field. It is waterproof up to 305 m (1000 feet) and rugged enough to withstand years of use. It has enough memory to record over 42,000 12-bit temperature measurements.

The logger uses an optical USB communications interface (via a compatible shuttle or base station) for launching and reading out the logger. The optical interface allows the logger to be offloaded without compromising the electronics. The USB compatibility allows for easy setup and fast downloads.

HOBOWare® 2.2 or later is required for logger operation. Visit www.onsetcomp.com for compatibility information.

Specifications

Temperature Sensor	
Operation range*	-20° to 70°C (-4° to 158°F) in air; maximum sustained temperature of 30°C (86°F) in water*
Accuracy	0.2°C over 0° to 50°C (0.36°F over 32° to 122°F), see Plot A
Resolution	0.02°C at 25°C (0.04°F at 77°F), see Plot A
Response time	5 minutes in water; 12 minutes in air moving 2 m/sec; 20 minutes in air moving 1 m/sec (typical to 90%)
Stability (drift)	0.1°C (0.18°F) per year
Logger	
Real-time clock	± 1 minute per month 0° to 50°C (32° to 122°F)
Battery	3 Volt lithium, non-replaceable
Battery life (typical use)	5 years with 1 minute or greater logging interval
Memory (non-volatile)	64K bytes memory (approx. 42,000 12-bit temperature measurements)
Weight	23 g (0.8 oz)
Dimensions	3.0 × 4.1 × 1.7 cm (1.2 × 1.6 × 0.65 in.); mounting bail 4.6 mm (3/16 in.) diameter
Wetted materials	Epoxy case
Waterproof	To 305 m (1000 ft.)
Logging interval	Fixed-rate or multiple logging intervals, with up to 8 user-defined logging intervals and durations; logging intervals from 1 second to 18 hours. Refer to HOBOWare software manual.
Launch modes	Immediate start, delayed start, triggered start
Offload modes	Offload while logging; stop and offload
Battery indication	Battery level can be viewed in status screen and optionally logged in datafile. Low battery indication in datafile.
NIST certificate	Available for additional charge
CE	The CE Marking identifies this product as complying with the relevant directives in the European Union (EU).

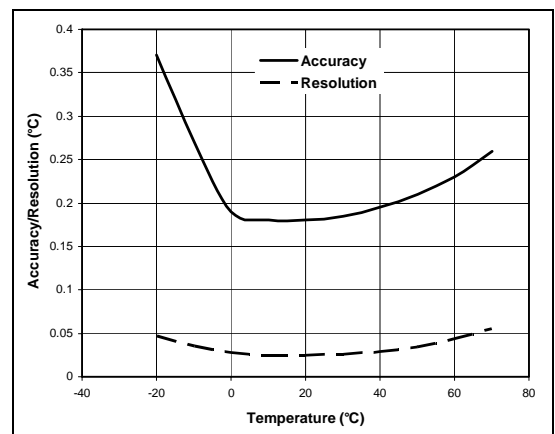

Plot A

* To guarantee accuracy, the TidbiT v2 Temp must not be used in condensing environments and water temperatures higher than 30C (86F) for more than eight cumulative weeks over the life of the logger. Frequent or prolonged exposure will lead to measurement drift and eventual failure.

Accessories available

- Black protective boot, 5-pack (part # BOOT-TIDBIT-BK)
- White protective boot, 5-pack (part # BOOT-TIDBIT-WH)

Connecting the logger

The TidbiT v2 Temp requires a coupler (Part # COUPLER2-D) and USB-Optic Base Station (Part # BASE-U-4) or HOBO Waterproof Shuttle (Part # U-DTW-1) to connect to the computer.

1. Install the logger software on your computer before proceeding.
2. Follow the instructions that came with your base station or shuttle to attach the base station or shuttle to a USB port on the computer.
3. Wipe the logger with a nonabrasive cloth, if necessary, to ensure that the logger’s communication LEDs are clean and dry.
4. Attach the coupler to the base station, then insert the logger into the coupler with the communication LEDs facing into the coupler, as shown in the diagram. When properly seated, the logger should be nearly flush with the top of the coupler.

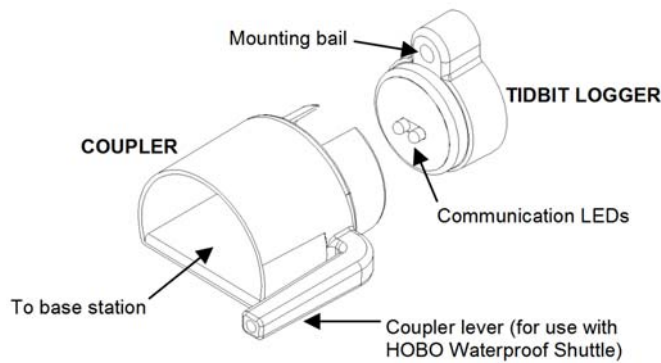

5. If you are using the HOBO Waterproof Shuttle, briefly press the coupler lever to put the shuttle into base station mode.
6. If the logger has never been connected to the computer before, it may take a few seconds for the new hardware to be detected by the computer.
7. Use the logger software to launch the logger, check the logger’s status, read it out, stop it manually with the software, or let it record data until the memory is full. Or, use the HOBO Waterproof Shuttle to read out and relaunch the logger in the field.

Refer to the software user’s guide for complete details on launching, reading out, and viewing data from the logger.

Important: USB communications may not function properly at temperatures below 0°C (32°F) or above 50°C (122°F).

Note: The logger consumes significantly more battery power when it is “awake” and connected to a base station or shuttle. To conserve power, the logger will go into a low-power (sleep) mode if there has been no communication with your computer for 30 minutes. To wake up the logger, remove the logger from the coupler, wait a moment, then re-insert the logger.

Note: The first time you launch the logger, the deployment number will be greater than zero. Onset launches the loggers to test them prior to shipping.

Operation

An “OK” light (LED) on the front of the logger confirms logger operation. (In brightly lit areas, it may be necessary to shade the logger to see the “OK” light blink.) The following table explains when the “OK” light blinks during logger operation:

When:	The “OK” light:
The logger is logging	Blinks once every one to four seconds (the shorter the logging interval, the faster the light blinks); blinks when logging a sample
The logger is awaiting a start because it was launched in Start At Interval, Delayed Start or Triggered Start mode	Blinks once every eight seconds until logging begins

Triggered launch

The TidbiT v2 Temp has an optional triggered launch. Launch your logger choosing the triggered launch option. The magnetically operated reed switch is activated when the Tidbit Coupler is reconnected to the logger for 2 seconds and then removed. The base station and coupler are not necessary to trigger the launch. Any strong magnet placed near the face of the logger will trigger the launch. The TidbiT v2 Temp’s red LED light will rapidly flash four times to indicate successful triggered launch.

Sample and event logging

The logger can record two types of data: samples and events. Samples are the sensor measurements recorded at each logging interval (for example, temperature every minute). Events are independent occurrences triggered by a logger activity, such as Bad Battery or Host Connected. Events help you determine what was happening while the logger was logging.

The logger stores 64K of data, and can record over 42,000 12-bit temperature measurements.

Deploying and protecting the logger

- Depending on water conditions and desired measurement location, the logger should be appropriately weighted, secured, and protected.
- The mounting bail on the logger accepts 1/8 inch (4 mm) diameter nylon cord or other strong cable. If wire is used to secure the logger, make sure the wire loop is snug to the bail. Any slack in the loop may cause excessive wear.
- This logger should not be immersed in any liquid other than fresh or salt water. To do so may damage the epoxy case and void the warranty (refer to the Service and Support section). If you have any questions about chemical resistance, call Onset.
- To clean the logger, rinse it in warm water. Use a mild dishwashing detergent if necessary. Do not use harsh chemicals, solvents, or abrasives, especially on the communications LEDs.

Battery

The battery in the TidbiT v2 Temp is a non-replaceable 3-Volt lithium battery. The battery life of the logger should be about five years. Actual battery life is a function of the number of deployments, logging interval, and operation/storage temperature of the logger. To obtain a five-year battery life, a logging interval of one minute or greater should be used and the logger should be operated and stored at temperatures between 0° and 25°C (32° and

77°F). Frequent deployments with logging intervals of less than one minute, and continuous storage/operation at temperatures above 35°C, will result in significantly lower battery life. For example, continuous logging at a one-second logging interval will result in a battery life of approximately one month.

The logger can report and log its own battery voltage. If the battery falls below 2.7 V, the logger will record a “bad battery” event in the datafile. If the battery fails, dispose of the logger according to local regulations. Do not attempt to open the logger case. The battery is not replaceable, and the logger does not contain any user-serviceable parts. If you open the case, the logger will be unusable, and the warranty will be voided.

⚠ WARNING: Do not cut open, incinerate, heat above 100°C (212°F), or recharge the lithium battery. The battery may explode if the logger is exposed to extreme heat or conditions that could damage or destroy the battery case. Do not dispose of the logger or battery in fire. Do not expose the contents of the battery to water. Dispose of the battery according to local regulations for lithium batteries.

Service and Support

As part of Onset’s ongoing efforts to provide 100% customer satisfaction, our Continuing Engineering Group constantly monitors and evaluates all of our products and software. In the unlikely event any significant defect is found, Onset will notify you. If you find a defect, please e-mail us at loggerhelp@onsetcomp.com.

HOBO products are easy to use and reliable. In the unlikely event that you have a problem with this instrument, contact the company where you bought the logger: Onset or an Onset Authorized Dealer. Before calling, you can evaluate and often solve the problem if you write down the events that led to the problem (are you doing anything differently?) and if you visit the Technical Support section of the Onset web site at www.onsetcomp.com/support.html. When contacting Onset, ask for technical support and be prepared to provide the product number and serial number for the logger and software version in question. Also completely describe the problem or question. The more information you provide, the faster and more accurately we will be able to respond.

Onset Computer Corporation
 470 MacArthur Blvd., Bourne, MA 02532
 Mailing: PO Box 3450, Pocasset, MA 02559-3450
 Phone: 1-800-LOGGERS (1-800-564-4377) or 508-759-9500
 Fax: 508-759-9100
 E-mail: loggerhelp@onsetcomp.com
 Internet: www.onsetcomp.com

Warranty

Onset Computer Corporation (Onset) warrants to the original end-user purchaser for a period of **one year** from the date of original purchase that the HOBO® product(s) purchased will be free from defect in material and workmanship. During the warranty period Onset will, at its option, either repair or replace products that prove to be defective in material or workmanship. This warranty shall terminate and be of no further effect at the time the product is (1) damaged by extraneous cause such as fire, water, lightning, etc. or not maintained in accordance with the accompanying documentation; (2) modified; (3) improperly installed; (4) repaired by someone other than Onset; or (5) used in a manner or purpose for which the product was not intended.

THERE ARE NO WARRANTIES BEYOND THE EXPRESSED WARRANTY ABOVE. IN NO EVENT SHALL ONSET BE LIABLE FOR LOSS OF PROFITS OR INDIRECT, CONSEQUENTIAL, INCIDENTAL, SPECIAL OR OTHER SIMILAR DAMAGES ARISING OUT OF ANY BREACH OF THIS CONTRACT OR OBLIGATIONS UNDER THIS CONTRACT, INCLUDING BREACH OF WARRANTY, NEGLIGENCE, STRICT LIABILITY, OR ANY OTHER LEGAL THEORY.

Limitation of Liability. The Purchaser's sole remedy and the limit of Onset's liability for any loss whatsoever shall not exceed the Purchaser's price of the product(s). The determination of suitability of products to the specific needs of the Purchaser is solely the Purchaser's responsibility. **THERE ARE NO WARRANTIES BEYOND THE EXPRESSED WARRANTY OFFERED WITH THIS PRODUCT. EXCEPT AS SPECIFICALLY PROVIDED IN**

THIS DOCUMENT, THERE ARE NO OTHER WARRANTIES EXPRESS OR IMPLIED, INCLUDING BUT NOT LIMITED TO, ANY IMPLIED WARRANTIES OF MERCHANTABILITY OR FITNESS FOR A PARTICULAR PURPOSE. NO INFORMATION OR ADVICE GIVEN BY ONSET, ITS AGENTS OR EMPLOYEES SHALL CREATE A WARRANTY OR IN ANY WAY INCREASE THE SCOPE OF THE EXPRESSED WARRANTY OFFERED WITH THIS PRODUCT.

Indemnification. Products supplied by Onset are not designed, intended, or authorized for use as components intended for surgical implant or ingestion into the body or other applications involving life-support, or for any application in which the failure of the Onset-supplied product could create or contribute to a situation where personal injury or death may occur. Products supplied by Onset are not designed, intended, or authorized for use in or with any nuclear installation or activity. Products supplied by Onset are not designed, intended, or authorized for use in any aeronautical or related application. Should any Onset-supplied product or equipment be used in any application involving surgical implant or ingestion, life-support, or where failure of the product could lead to personal injury or death, or should any Onset-supplied product or equipment be used in or with any nuclear installation or activity, or in or with any aeronautical or related application or activity, Purchaser will indemnify Onset and hold Onset harmless from any liability or damage whatsoever arising out of the use of the product and/or equipment in such manner.

Returns

Please direct all warranty claims and repair requests to place of purchase.

Before returning a failed unit directly to Onset, you must obtain a Return Merchandise Authorization (RMA) number from Onset. You must provide proof that you purchased the Onset product(s) directly from Onset (purchase order number or Onset invoice number). Onset will issue an RMA number that is valid for 30 days. You must ship the product(s), properly packaged against further damage, to Onset (at your expense) with the RMA number marked clearly on the outside of the package. Onset is not responsible for any package that is returned without a valid RMA number or for the loss of the package by any shipping company. Loggers must be clean before they are sent back to Onset or they may be returned to you.

Repair Policy

Products that are returned after the warranty period or are damaged by the customer as specified in the warranty provisions can be returned to Onset with a valid RMA number for evaluation.

ASAP Repair Policy. For an additional charge, Onset will expedite the repair of a returned product.

Data-back™ Service. HOBO data loggers store data in nonvolatile EEPROM memory. Onset will, if possible, recover your data.

Tune Up Service. Onset will examine and retest any HOBO data logger.

© 2006, 2007 Onset Computer Corporation. All rights reserved.
 Part #: MAN-UTBI-001, Doc #: 10385-C, Patent #: 6,826,664

Onset, HOBO, TidbiT, and HOBOWare are registered trademarks of Onset Computer Corporation. Other products and brand names may be trademarks or registered trademarks of their respective owners.